

Chapter 7 Checks and Maintenance

7.1 Check and Maintenance Lists (SPH(H)-102/202/302)

7.1.1 Check list

For an explanation on each check item, see below Table 7.1.

If any of the following checks result bad, contact the place of purchase or ESPEC CORP.

Table 7.1 Check list

Check item	When to check
Main power switch (leakage breaker) trip test	<ul style="list-style-type: none"> • Once monthly • Before long test runs
Overheat protector trip test	Before every test

7.1.2 Maintenance list

For an explanation on each maintenance item, see below Table 7.2.

Table 7.2 Maintenance list

Maintenance item	When to perform
Cleaning Inside the Chamber	After every test
Cleaning the Exhaust Damper	Once every 2 or 3 months
Electric parts compartment cleaning	Once every 2 or 3 months
Cleaning Inside the Exhaust Duct	Once every 2 or 3 months
Take-Down Before Long Periods of Disuse	Before long periods of disuse
Replacing Cartridge Fuses	Whenever a cartridge fuse blows
Grease-job to the handle	Once yearly

7.2 Check and Maintenance Lists (SPH(H)-402)

7.2.1 Check list

For an explanation on each check item, see below Table 7.3.

If any of the following checks result bad, contact the place of purchase or ESPEC CORP.

Table 7.3 Check list

Check item	When to check
Main power switch (leakage breaker) trip test	<ul style="list-style-type: none"> • Once monthly • Before long test runs
Overheat protector trip test	Before every test

7.2.2 Maintenance list

For an explanation on each maintenance item, see below Table 7.4.

Table 7.4 Maintenance list

Maintenance item	When to perform
Cleaning Inside the Chamber	After every test
Cleaning the Exhaust Damper	Once every 2 or 3 months
Electric parts compartment cleaning	Once every 2 or 3 months
Cleaning Inside the Exhaust Duct	Once every 2 or 3 months
Take-Down Before Long Periods of Disuse	Before long periods of disuse
Replacing Cartridge Fuses	Whenever a cartridge fuse blows

7.3 Main Power Switch (Leakage Breaker) Trip Test



WARNING



Perform an operation test on the leakage breaker and check that it is operating normally before starting chamber operation.

Failing to do so can result in electric shock.

Once a month and before long test runs, test-trip the main power switch (leakage breaker). With the main power switch in the ON position, press the test button. If the switch's lever falls to the middle position, the breaker is working properly.

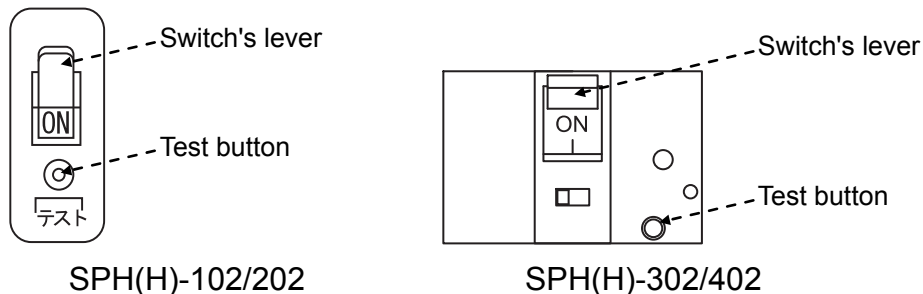



Fig. 7.1 Test button

◆ Note ◆

When the leakage breaker in the main power switch of SPH(H)-302, 402 trips, the switch's lever falls halfway between the ON and OFF positions. To turn power back ON again, first set the switch to the OFF position and then to the ON position.

7.4 Overheat Protector Trip Test



WARNING

! Before starting chamber operation, correctly set the safety device for overheat protection and check that this device is operating normally.

Failing to do so can result in fire.

Before starting operation, test the overheat protector for proper tripping.

<Procedure>

- 1) Check the main power switch (leakage breaker) is in the ON position.
- 2) Press  key.
- 3) Set the overheat protector temperature below the actual chamber temperature.

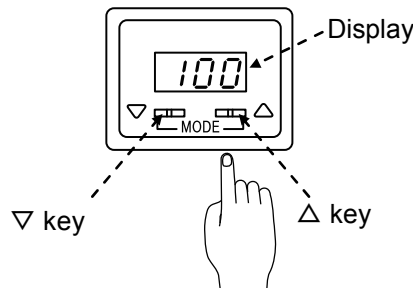

Fig. 7.2 Overheat Protector



- 4) If the overheat protector is functioning properly, an alarm will be generated: a fault indication lamp will light up and the buzzer will sound. If an alarm is not generated, there is something wrong with the overheat protector. Contact the place of purchase or ESPEC CORP.

ALARM !	03 / 10
E06 OVER HEAT	

- 5) Reset the overheat protector.
To clear the alarm, press the  key to shut OFF power to the chamber.

7.5 Cleaning Inside the Chamber

Dirt and foreign matter inside the test area can throw test results off. Clean the test area after every test.

 CAUTION	
	Immediately after operation ends, the chamber is hot on the inside (specimens, shelf, door gasket and test area walls). Therefore, allow it to cool sufficiently before cleaning inside.

<Procedure>

- 1) Open the chamber door.
- 2) Wipe walls and parts clean with a soft cloth.
- 3) Close the door.

7.6 Cleaning the Exhaust Damper (SPH(H)-102/202/302)

If specimens release vapor, clean the exhaust damper about every 2 to 3 months.



WARNING



Turn OFF the power switch (leakage breaker), and wear rubber or leather gloves before cleaning the exhaust damper. Do not contact parts other than the exhaust damper.

◆ Note ◆

- Fully close the exhaust damper to clean it.
- Special heat protected screws are used to lock down the exhaust damper maintenance port cover, therefore do not replace them with other types of screws.
- Do not turn the screws too much to reattach the exhaust damper maintenance port cover. Over-tightening of the screws will cause the district distorting in shape.

<Procedure>

- 1) Open the door.
- 2) Remove the shelves and detach the shelf brackets.
- 3) Remove the register positioned left-below inside test area.

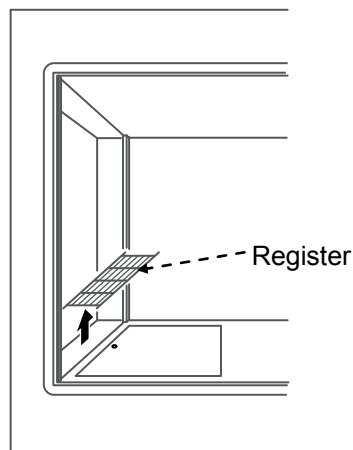

Fig. 7.3 Removing the register

- 4) Remove the screws that lock down the exhaust damper maintenance port cover and detach the cover. This will require a Philips screwdriver.

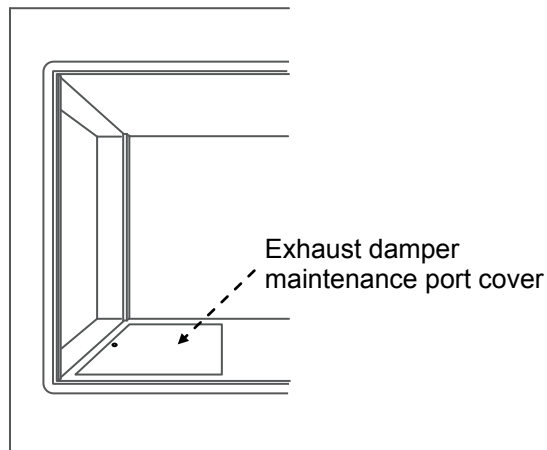

Fig. 7.4 Exhaust damper maintenance port cover

- 5) Remove the screws that lock down the exhaust damper and detach the exhaust damper. This will require a Philips screwdriver.

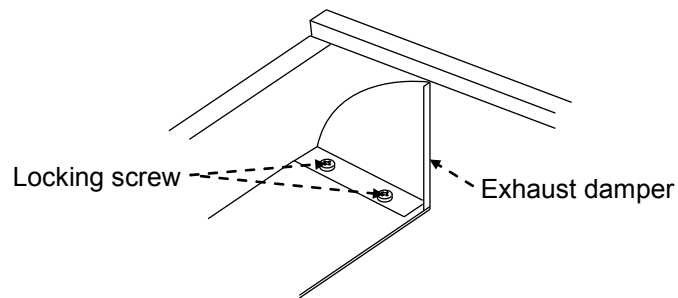



Fig. 7.5 Removing the exhaust damper

- 6) Wipe the exhaust damper with a soft piece of cloth, etc.
- 7) Reattach the exhaust damper and the exhaust damper maintenance port cover as before.
- 8) Reattach the register as before.

7.7 Cleaning the Exhaust Damper (SPH(H)-402)

If specimens release vapor, clean the exhaust damper about every 2 to 3 months.

 WARNING	
	Turn OFF the power switch (leakage breaker), and wear rubber or leather gloves before cleaning the exhaust damper. Do not contact parts other than the exhaust damper.

◆ Note ◆	
	<ul style="list-style-type: none">• Fully close the exhaust damper to clean it.• Special heat protected screws are used to lock down the exhaust damper maintenance port cover, therefore do not replace them with other types of screws.

<Procedure>

- 1) Open the door.
- 2) Remove the shelves and detach the shelf brackets.
- 3) Remove the screws that lock down the exhaust damper maintenance port cover and open the cover. This will require a Philips screwdriver.

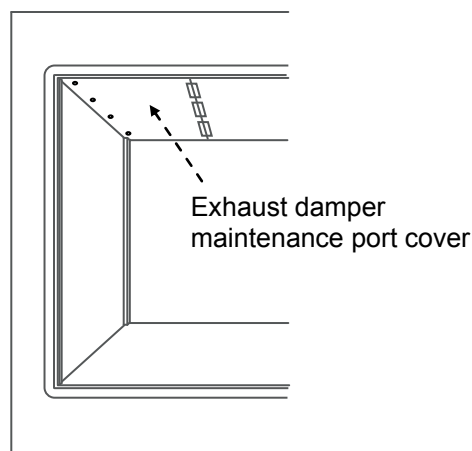

Fig. 7.6 Exhaust damper maintenance port cover

- 4) Wipe the exhaust damper with a soft piece of cloth, etc.

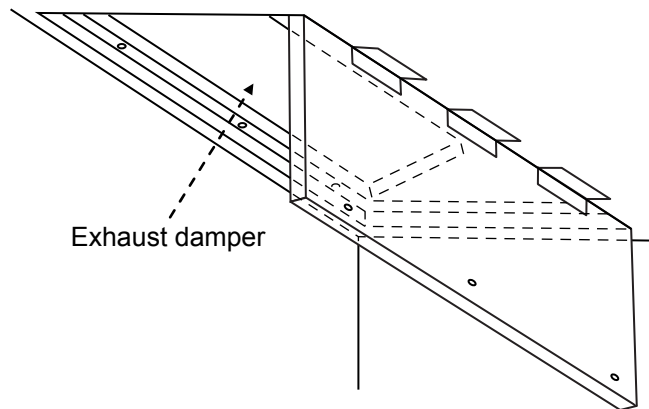



Fig. 7.7 Exhaust damper

- 5) Reattach the exhaust damper maintenance port cover as before.

7.8 Electric Parts Compartment Cleaning

Because the electric compartment is ventilated, dust easily accumulates inside. Dust accumulation may cause leakage and faulty contacts.

Clean inside the electrical compartment once every 2 or 3 months with a vacuum cleaner.

 WARNING	
	ELECTRIC SHOCK! Shut OFF primary power supply BEFORE cleaning the electric parts compartment.
	Cleaning it while power is ON runs the risk of electric shock.

<Procedure>

- 1) Check the main power switch is in the OFF position.
- 2) Loosen the screws that lock down the electric parts compartment cover and detach the cover.
- 3) Clean dirt from the compartment with a vacuum cleaner or by other means.
- 4) Reattach the compartment cover.

7.9 Cleaning Inside the Exhaust Duct



WARNING



Be sure to clean inside the exhaust duct, whether of our manufacture or installed by you, once every 2 or 3 months.

The vapor from specimens or airborne substances may settle inside the exhaust duct as sludge. Accumulated sludge may be ignited by the hot air of the exhaust.

<Procedure>

- 1) Detach the exhaust duct from exhaust port.
- 2) Wipe inside the exhaust duct clean with waste cloth.
- 3) Reattach the exhaust duct.

7.10 Take-Down Before Long Periods of Disuse



■ Shut OFF power supply

Set the main power switch (leakage breaker) in the OFF position and shut OFF primary power supply.

7.11 Replacing Cartridge Fuses (SPH(H)-102/202/302)

Over prolonged testing, cartridge fuses can weaken and blow. When a fuse blows, replace it as explained below.

Check the capacity of the blown fuse and replace it with one of the same capacity.

 WARNING	
	<p>Use appropriate methods, as shown below, to replace and inspect the fuse.</p> <p>Failing to do so can result in electric shock.</p>

◆ **Note** ◆

If a new fuse blows as soon power is turned back ON, contact the place of purchase or ESPEC CORP.

<Procedure>

- 1) Check the main power switch (leakage breaker) is in the OFF position.
- 2) Loosen the screws that lock down the electric parts compartment cover and detach the cover.
- 3) Replace the blown cartridge fuse with a new one.
Cartridge fuses for SPH(H)-102/202 and for SPH(H)-302 are positioned in different locations.
- 4) Reattach the electric parts compartment cover as before.

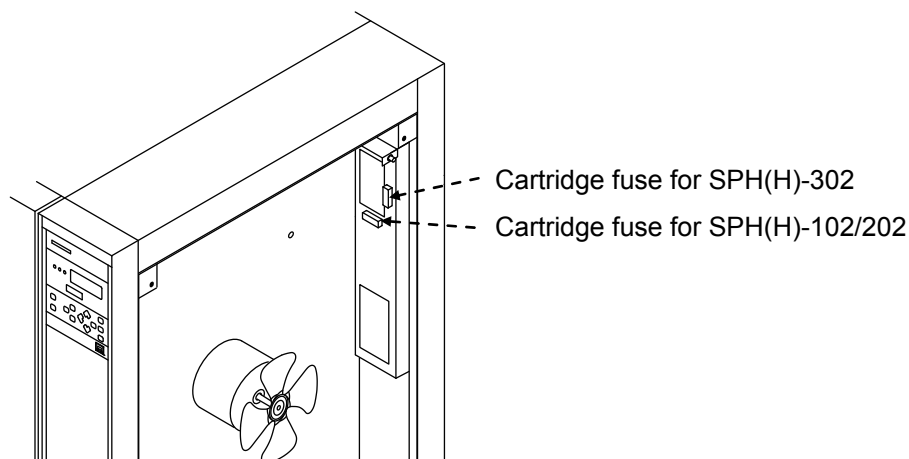

Fig. 7.8 Replacing cartridge fuse

Table 7.5 Fuse capacity

		SPH(H)-102	SPH(H)-202	SPH(H)-302
200V AC specification	3A	○	○	-
	5A	-	-	○
220V AC specification	3A	○	○	-
	5A	-	-	○
230V AC specification	3A	○	○	-
240V AC specification	3A	○	○	-
380V AC specification	3A	-	-	○
	5A	-	-	○

7.12 Replacing Cartridge Fuses (SPH(H)-402)

Over prolonged testing, cartridge fuses can weaken and blow. When a fuse blows, replace it as explained below.

Check the capacity of the blown fuse and replace it with one of the same capacity.

WARNING	
	<p>Use appropriate methods, as shown below, to replace and inspect the fuse.</p> <p>Failing to do so can result in electric shock.</p>

◆ Note ◆
<p>If a new fuse blows as soon power is turned back ON, contact the place of purchase or ESPEC CORP.</p>

<Procedure>

- 1) Check the main power switch (leakage breaker) is in the OFF position.
- 2) Loosen the screws that lock down the electric parts compartment cover and detach the cover.
- 3) Replace the blown cartridge fuse with a new one.
- 4) Reattach the electric parts compartment cover as before.

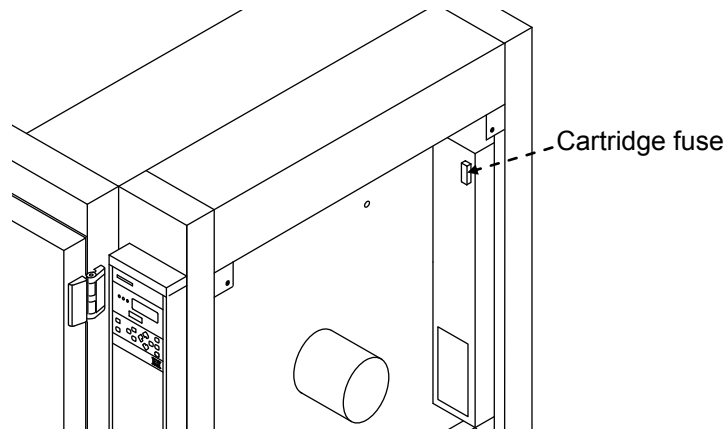

Fig. 7.9 Replacing cartridge fuse

Table 7.6 Fuse capacity

		SPH(H)-402
200V AC specification	3A	○
220V AC specification	3A	○
380V AC specification	2A	○
	3A	○

7.13 Greas-job to the handle

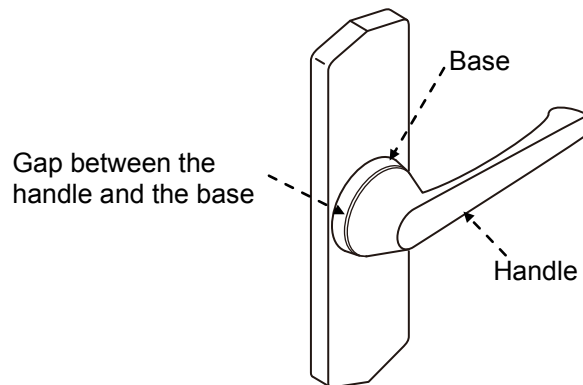

Fig. 7.10 Grease-job to the handle

Grease-job once per a year

Grease-job has to be done after stop the chamber operation.

After the grease-job, turn the handle twice.

Grease: Spray grease(Urea)

ex) Grease mate(Kure Engineering)