

Chapter 7

Checks and Maintenance

This chapter explains equipment checks and maintenance. To keep the chamber in good working condition, perform checks and maintenance periodically.

7.1 Check and Maintenance Lists

■ Check list

For an explanation on each check item, see "7.2 Checks".

If any of the following checks result bad, contact the place of purchase or ESPEC CORP.

Table 7.1 Check list

Check item	When to check
Main power switch (leakage breaker) trip test	<ul style="list-style-type: none"> • Once monthly • Before long test runs
Overheat protector trip test	<ul style="list-style-type: none"> • Before every test
Water level check for humidifying tray and humidifying tray water level regulator	<ul style="list-style-type: none"> • Once every 3 months • After moving chamber (See "4.4 Water Level Check".)

■ Maintenance list

For an explanation on each maintenance item, see "7.3 Maintenance".

Table 7.2 Maintenance list

Maintenance item	When to perform
Condenser filter cleaning	Once monthly
Water tank (auxiliary and main) and tank filter cleaning (Not necessary with temperature-only chambers)	Once monthly
Water supply pump filter cleaning (Not necessary with temperature-only chambers)	Once monthly
Humidifying tray cleaning (Not necessary with temperature-only chambers)	Once monthly
Test area cleaning	Before every test
Electric parts compartment and water circuit compartment cleaning	Once yearly
Take-down	Before long periods of disuse

7.2 Checks

Main Power Switch (Leakage Breaker) Trip Test

Once a month and before long test runs, test-trip the main power switch (leakage breaker).

With the main power switch in the ON position, press the test button. If the switch's lever falls to the middle position, the breaker is working properly.

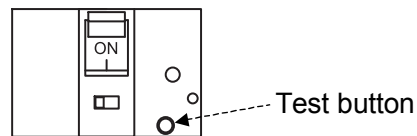

Fig. 7.1 Test button

Reference When the leakage breaker in the main power switch trips, the switch's lever falls halfway between the ON and OFF positions. To turn power back ON again, first set the switch to the OFF position and then to the ON position.

Overheat Protector Trip Test

Before every test, test-trip the overheat protector.

- Procedure**
1. Check the main power switch is in the ON position.
 2. Press the **POWER** key to activate control power.
The display will come on and the main menu will appear shortly.
 3. Press either the **OPER./STOP** key on the operating panel or the chamber operating status box on the screen to get the Operation Mode Selection screen. Then, press the **START** button under Constant Mode followed by the **Yes** button on the confirmation message.
The chamber will start up.

4. Set the overheat protector about 5°C lower than chamber temperature.

If the overheat protector is working properly, a buzzer will sound and the Alarm screen will be appear on the display when temperature inside the chamber reaches the overheat protector setting.

If a buzzer is not sounded, something is wrong with the equipment. Contact the place of purchase or ESPEC CORP.

5. To silence the buzzer, press the button on the Alarm screen.

7.3 Maintenance

Condenser Filter Cleaning

Clean the condenser filter so as to prevent dust from adhering to the condenser.

- Procedure**
1. Remove the condenser filter.
Type 3 chambers have one filter, whereas type 5 chambers have two. In both cases, the filters are located to the rear of the water tank drawer.

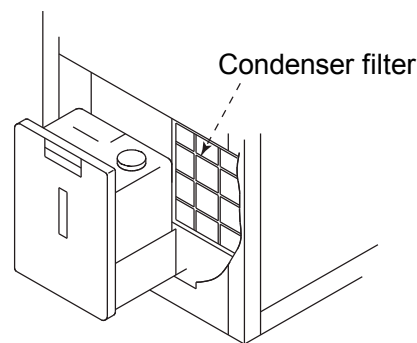

Fig. 7.2 How to remove the condenser filter

2. Rinse the filter clean of dust and dirt with plain water.
3. Drip off water and dry in a dark place.
The condenser filter is made of plastic. Direct exposure to sunlight can deform it.
4. Reinstall the filter as before.

Water Tank and Tank Filter Cleaning

(Not necessary with temperature-only chambers)

Water can stagnate if left inside the water tank for 1 month or longer. Stagnate water will shorten the service-life of the humidifying heater and wet-bulb wick. Therefore, clean the water tank and tank filter once a month.

There are two water tanks; the main tank is stationary while the auxiliary tank is portable. The main water tank has a filter and frame on the water supply port. To remove the filter, hold it by the projecting stub and jiggle it in all directions while lifting upward.

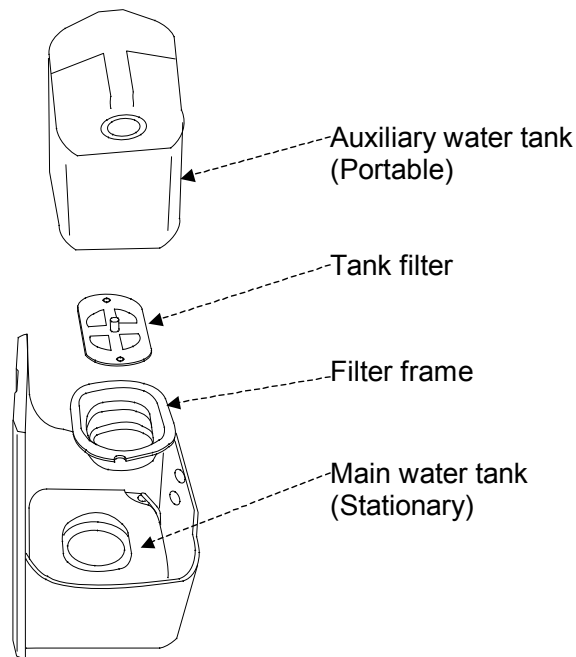

Fig. 7.3 Water tanks and filter

CAUTION

- **Return all parts to their original positions after cleaning.**
Improperly installed parts or missing parts can cause leaks or disable water supply.
- **Snap the bottom edges of the filter frame onto the ledges of the water supply port on the main water tank.**

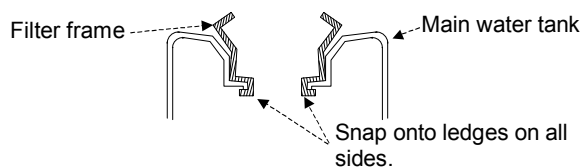

Fig. 7.4 Filter frame

- **Press the filter fully to the bottom of the filter frame.**

■ **To clean the auxiliary water tank**

- Procedure**
1. Remove the auxiliary water tank from the water tank drawer.
 2. Open the lid and add about 2 L of water.
 3. Shake the tank in all directions to clean the inside.
 4. Press the valve on the bottom of the tank and drain the water.

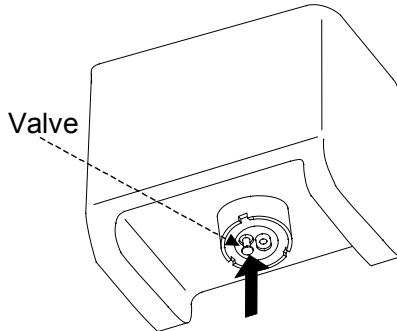



Fig. 7.5 Draining the auxiliary water tank

5. Repeat steps 2 to 4 two or three times.
6. Return the auxiliary water tank to its original position.

■ **To clean the main water tank**

 CAUTION
<ul style="list-style-type: none"> • Stop the chamber before cleaning the main water tank. Also, supply water to the humidifying tray after cleaning the tank. Water supply automatically purges the water circuit of air which serves to properly maintains water supply rate.

- Procedure**
1. Remove the auxiliary water tank from the water tank drawer, and remove the tank filter and filter frame from the main water tank.
 2. Clean the main tank on the inside with a brush or cloth.
 3. Add some water to the main tank.

- Free the hose from the hose clip, disconnect it at the coupling and drain the tank.

The hose is located toward the rear of the water tank drawer.

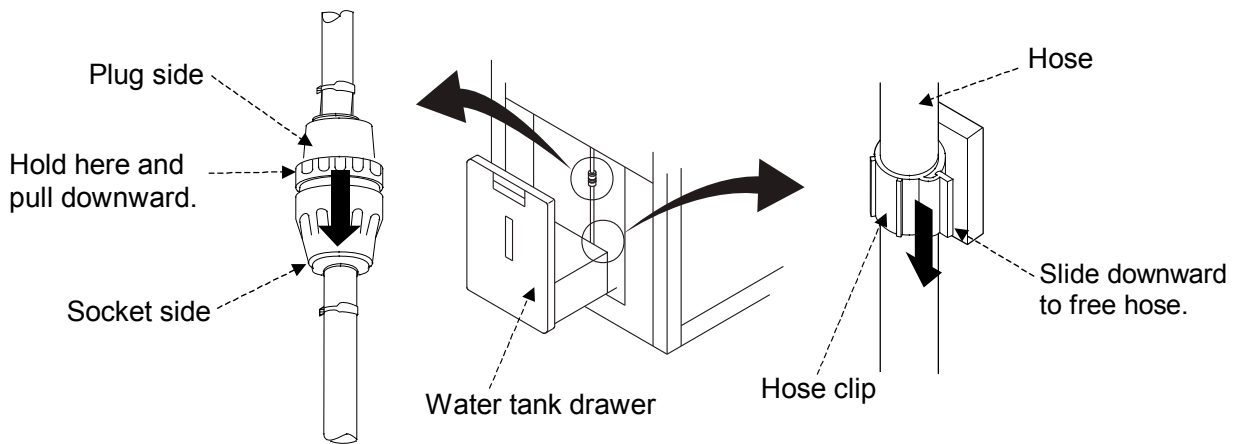

Fig. 7.6 Disconnecting the hose

- Blot up any excess water from inside the main tank with a piece of cloth.
- Reinstall the filter frame, tank filter and the auxiliary water tank as before.

■To clean the tank filter

Procedure

- Remove the auxiliary water tank from the main water tank, and remove the tank filter.
- Rinse the filter clean of dirt with plain water.
- Reinstall the tank filter and the auxiliary water tank as before.

Water Supply Pump Filter Cleaning (Not necessary with temperature-only chambers)

The water supply pump is fitted with a filter so as to prevent dirt from infiltrating the wick pan and humidifying tray water supply pumps. Clean the filter once a month.

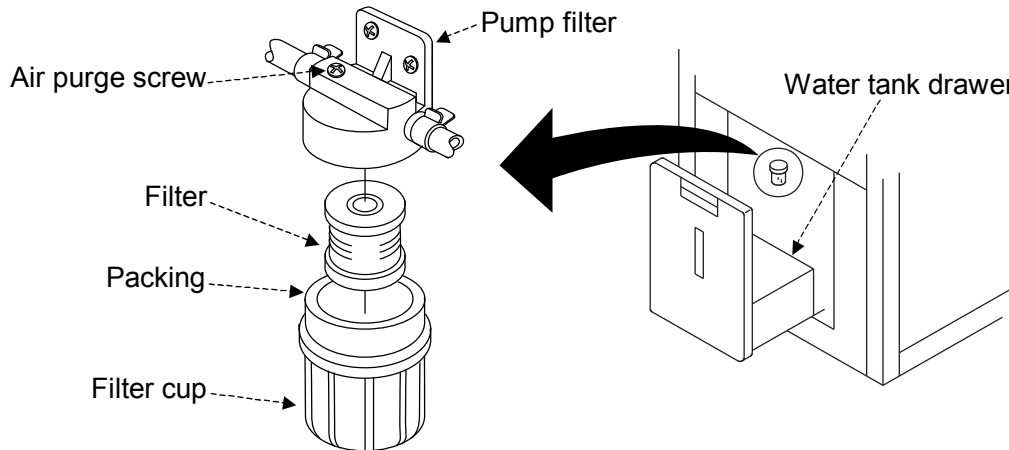

Fig. 7.7 Water supply pump filter



CAUTION

- **Stop the chamber before cleaning the water supply pump filter. Also, after cleaning, supply water to the humidifying tray so as to purge the supply line of air.**
This air purge helps keep water in the tray to the proper level.

- Procedure**
1. Check the main power switch is in the OFF position.
 2. Remove the auxiliary (portable) water tank from the water tank drawer.
 3. Turn the pump filter cup until detaching. (Lay rags below the cup to blot up spilling water.)
 4. Pull the filter out from the bottom of the pump filter casing.
 5. Rinse the filter clean of dirt with plain water.
 6. Reassemble parts as before.
 7. Supply water to the humidifying tray. (Run a temperature-humidity test.)
 8. Remove the air purge screw. Retighten the screw when water trickles from the hole.

Humidifying Tray Cleaning (Not necessary with temperature-only chambers)

CAUTION

- **SHARP EDGES! Be careful of projections or sharp edges inside the chamber.**
For your safety, always wear gloves when working inside the chamber.
- **HOT ON THE INSIDE! Cool down the test area before cleaning the humidifying tray.**
During and shortly after operation above 55°C, the chamber is HOT and HUMID on the inside (specimens, shelves, door gasket, test area walls).

During operation, dirt and foreign matter stick to the humidifying tray and humidifying heater. To ensure long lasting use, clean the tray and heater of dirt once a month. A good way to inhibit dirt from accumulating is to drain the humidifying tray after every test.

- Procedure**
1. Open the chamber door.
 2. Lift the protective grille outwards from the bottom and then upwards to detach.

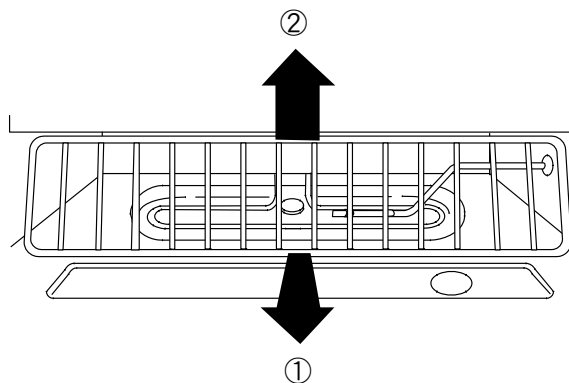

Fig. 7.8 How to detach the protective grille

3. Clean the surfaces of the humidifying tray and humidifying heater with a brush or other means.
4. Reattach the grille and close the chamber door.

Test Area Cleaning

Dirt and foreign matter inside the test area can throw test results off. Clean the test area before every test.

- Procedure**
1. Open the chamber door.
 2. Wipe walls and parts clean with a soft cloth.
 3. Close the door.

Electric Parts Compartment and Water Circuit Compartment Cleaning

Dust buildup inside the electric parts compartment or the water circuit compartment can lead to trouble. Clean inside both compartments once a month.

- Procedure**
1. Check the main power switch is in the OFF position.
 2. Detach the electric parts compartment and water circuit compartment doors.
 3. Clean dirt from both compartments with a vacuum cleaner or by other means.
 4. Reattach the compartment doors.

Take-Down Before Long Periods of Disuse

Before long periods of disuse, do the following. Failure to do so can affect testing and shorten equipment service-life.

- Replace the water in the water circuit. (Not necessary with temperature-only chambers)
- Drain the wick pan and humidifying tray of water. (Not necessary with temperature-only chambers)
- Dry the test area (run the chamber).
- Set the main power switch in the OFF position and shut OFF primary power supply.

■To replace the water in the water circuit (Not necessary with temperature-only chambers)

Set test area temperature and humidity to 70°C and 90%rh and run the chamber in the constant mode for approx. 10 min.

- Procedure**
1. Check the main power switch is in the ON position.
 2. Set the constant mode with temperature at 70°C and humidity at 90% rh.
 3. Get the Operation Mode Selection screen.
Press either the **OPER./STOP** key on the operating panel or the chamber operating status box on the screen.
 4. Press the **START** button under Constant Mode to start the chamber.
 5. Run the chamber for about 10 min with the door closed.

■To drain water (Not necessary with temperature-only chambers)

- Procedure**
1. Check the main power switch is in the ON position.
 2. Press the **POWER** key to activate control power.
 3. Hold the DRAIN switch in the "MANUAL" position for about 2 seconds.
Water will drain from the humidifying tray and wick pan.

■To dry the test area

The chamber is run to dry the test area.

Turn the refrigerator and humidity control OFF, and run the chamber at a minimum 70°C for about 60 minutes. After that, crack the chamber door slightly and run the chamber under the same conditions for about 15 minutes. As necessary, drain the humidifying tray manually (not necessary with temperature-only chambers).

- Procedure**
1. Check the main power switch is in the ON position.
 2. Turn refrigerator control OFF.
For an explanation on how to set refrigerator control, see "5.6 Handy Features".

3. Change settings so that the operation is not interrupted or an alarm generated if the chamber is run with the door cracked slightly. Make the following settings. For details on settings, see "Power Recovery Setup" in "5.11 Chamber Configuration" of the User's Manual - Reference -.
 - Select OFF next to Chamber Operation.
 - Press the ON box next to Hold Door Alarm so that the dot is black.
4. Set target temperature to a minimum 70°C and turn OFF humidity control (not necessary with temperature-only chambers).
5. Get the Operation Mode Selection screen. Press either the OPER./STOP key on the operating panel or the chamber operating status box on the screen.
6. Press the START button under Constant Mode to start the chamber.
Run the chamber for about 60 minutes with the door closed, then for 15 minutes with the door slightly cracked.
7. Return settings made in step 3 to their original settings.

Note | As necessary, drain the humidifying tray manually (not necessary with temperature-only chambers).

■Power OFF

Set the main power switch in the OFF position, then shut OFF the primary power supply.

