

8.2 Before You Call for Service

DANGER

- **ELECTRIC SHOCK! Before working on the power circuits on the primary side of the main power switch (leakage breaker), shut OFF primary power supply and check the line is dead. Also, take measures to prevent accidental charging.**

Working with primary power supply ON runs the risk of electric shock.

- **Shut OFF power from the main power switch (leakage breaker) BEFORE detaching the electric parts compartment door or the water circuit (heat exhaust) compartment door.**

This section explains troubles undetected in chamber self-checks and cases of misoperation which are easily mistaken as trouble. If the trouble cannot be remedied after taking the prescribed action, contact the place of purchase or ESPEC CORP.

Table 8.2 Before you call for service

Trouble	Cause	Remedial action
The instrumentation panel does not light up after pressing the POWER key.	Primary power supply is OFF.	Activate the primary power supply.
	The main power switch is in the OFF position.	Set the main power switch is in the ON position.
	The electric parts compartment or water circuit (heat exhaust) compartment door is open.	Close the door.
	There is a reverse or open phase in the primary power supply connection.	Reconnect the primary power supply correctly. See "4.4 Power Supply Work".
	Fuse F1 is blown.	Replace fuse F1. See "8.3 User Practical Servicing". If the new fuse blows, call for service.
The display goes out all of sudden or the displayed information is strange.	System trouble or internal board trouble	Switch the main power switch OFF and ON. If the same trouble reoccurs, call for service.
The door is hard to close.	Something is caught in the door.	Remove the obstruction.
	Frost has formed and hardened on the door packing.	Defrost the chamber. See "8.3 User Practical Servicing".
	Internal pressure is high because the chamber is hot and highly humid on the inside.	There is nothing wrong with the equipment. Proceed as planned.

Cont.

Trouble	Cause	Remedial action
The door is hard to open.	Internal pressure is lower than room pressure.	There is nothing wrong with the equipment. Proceed as planned.
	Frost has formed and hardened on the door packing.	Defrost the chamber. See "8.3 User Practical Servicing".
During operation below zero, icicles 5 cm or longer formed on the internal drain outlet, or the test area is covered in frost.	Outside air has infiltrated through the cable port.	Cover the cable port with the cap and rubber plug.
	Door packing is not properly sealing the door and frame, or packing has deteriorated.	Call for service.
Dew has formed around the door packing and the chamber front has a water leak	Door packing is not properly sealing the door and frame, or packing has deteriorated.	Call for service.
Strange noises are heard.	The fuse in the frost prevention heater blew and frost has formed on the air circulator blades.	Replace fuse F3. See "8.3 User Practical Servicing". If the new fuse blows, call for service.
	The condenser filter is clogged.	Clean the filter. See "7.3 Maintenance".
Strange odors are detected.	Lingering odors inside the chamber	Clean the test area. See "7.3 Maintenance".
	Specimens are generated odors.	There is nothing wrong with the equipment. Proceed as planned.
The chamber is vibrating.	The chamber is not level (adjuster feet are not the proper height).	Correct adjuster foot height. See "4.1 Installation".
The viewing window is clouded or frosted over.	Humidity rose sharply.	There is nothing wrong with the equipment. Proceed as planned.
	The fuse in the frost prevention heater blew.	Replace fuse F3. See "8.3 User Practical Servicing". If the new fuse blows, call for service.
The chamber is wet on the outside.	The room is highly humid.	There is nothing wrong with the equipment. Proceed as planned. End the operation after the temperature inside the chamber is returned to ambient temperature in order to prevent dripping the dew water and getting the floor wet.
Frost has formed around the door hinges, door and viewing window. (PSL, PG)	The room is highly humid.	There is nothing wrong with the equipment. Proceed as planned.
	The fuse in the frost prevention heater blew.	Replace fuse F4. See "8.3 User Practical Servicing". If the new fuse blows, call for service.
Wet-bulb wick is dry.	Bacteria are proliferating in the water tank.	Clean the water tank, the water tank filter, and the water supply pump filter. See "7.3 Maintenance"

Cont.

Trouble	Cause	Remedial action
Temperature (Humidity) is unstable.	The door is open.	Shut the door.
	The rubber plug fell off the cable port.	Fit the plug into the port.
	Ambient temperature changes more than 5°C/hr.	Stabilize ambient temperature and resume testing.
	High heat load equipment is being turned ON/OFF.	Reduce the heat load.
	The water supply pump filter is clogged.	Clean the filter. See "7.3 Maintenance".
Temperature gradually rises higher than the target temperature.	Specimens are generating heat.	Reduce the amount of heat generated by specimens.
	Frost has formed on the cooler.	Defrost the chamber. See "8.3 User Practical Servicing".
Temperature gradually rises higher than the target temperature.	Specimens are generating heat.	Reduce the amount of heat generated by specimens.
	Frost has formed on the cooler.	Defrost the chamber. See "8.3 User Practical Servicing".
Settings cannot be changed.	The keys are locked.	Unlock the keys.
Temperature lowers slowly.	This is a characteristic of rotary compressors. 5 to 10 minutes are needed before cooling starts.	There is nothing wrong with the equipment. Proceed as planned.
Temperature rises (lowers) too slowly.	The door is open.	Shut the door.
	Specimens are generating heat.	Reduce the amount of heat generated by specimens.
	Ambient temperature too low (high).	Raise (Lower) ambient temperature.
Temperature stops rising or begins to drop during heat-up.	Frost has formed on the dehumidifier-cooler.	There is nothing wrong with the equipment. Proceed as planned. Or, defrost the chamber. See "8.3 User Practical Servicing".
Poor temperature uniformity	Air flow inside the chamber is poor.	Improve air flow.
	Specimens are generating heat.	Reduce the amount of heat generated by specimens.
	Frost has formed on the cooler.	Defrost the chamber. See "8.3 User Practical Servicing".
The chamber lamp does not light up.	Fuse F2 is blown.	Replace fuse F2. See "8.3 User Practical Servicing". If the new fuse blows, call for service.
	The fluorescent bulb is blown.	Change the bulb. See "8.3 User Practical Servicing".
	The glow lamp is blown.	Change the lamp. See "8.3 User Practical Servicing".

Cont.

Trouble	Cause	Remedial action
Water is not supplied from the water tank (auxiliary tank).	The water tank (fixed) filter is clogged.	Clean the filter.
	The water tank (fixed) filter is damaged.	Replace the filter. See "7.3 Maintenance".
	The water tank (fixed) filter is not properly fitted.	Fit the filter properly. See "7.3 Maintenance".
Humidity does not lower.	Refrigerator control is OFF (manual mode), therefore cannot dehumidify test area.	Set refrigerator control to auto or 20%/50%/100% manual. See "3. Constant Mode Setup" or "4. Program Mode Setup" in the Reference Manual.

8.3 User Practical Servicing

Replacing Fuses

When a fuse blows, replace it with one of the included fuses.

Note If a new fuse blows soon after being installed, contact the place of purchase or ESPEC CORP.

- Procedure**
1. Set the main power switch in the OFF position.
 2. Detach the electric parts compartment door.
 3. Replace the blown fuse with a new one.

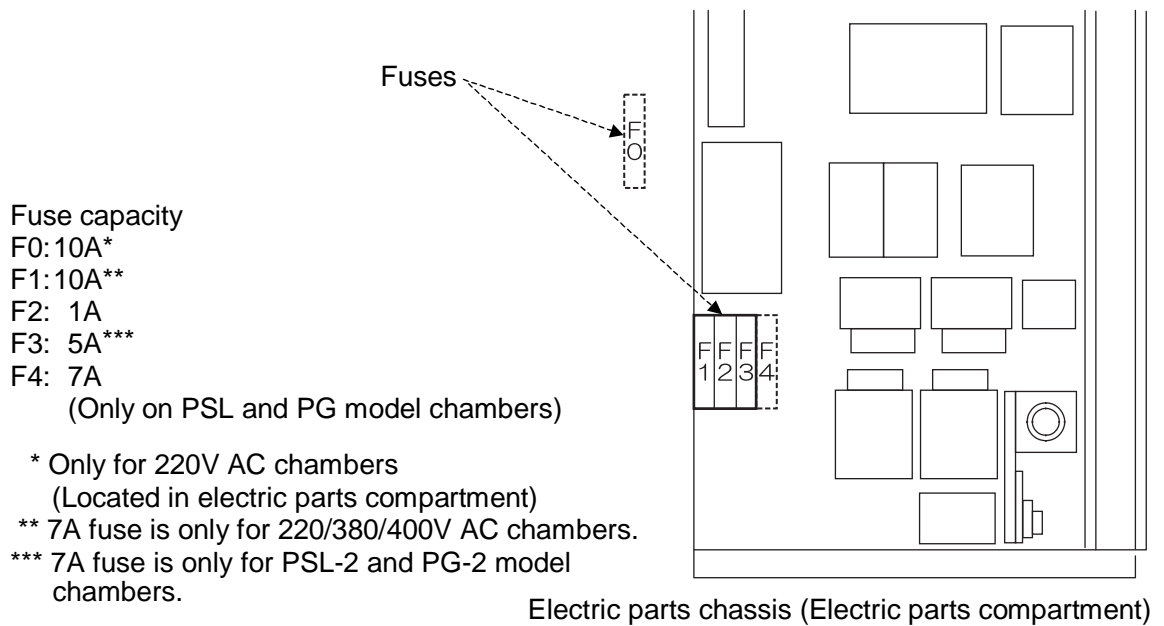

Fig. 8.1 Fuse location

4. Reattach the electric parts compartment door.

Changing the Chamber Lamp Bulb

Change the chamber lamp bulb after every 6,000 hours of service or whenever it blows. Use only the bulb (FPL9EX-N of Matsushita Electric Industrial or equivalent). Replacement will require a Phillips screwdriver.

 **CAUTION**

- **HOT! Shortly after the lamp goes out, it is HOT. Be careful of burns.**
- **FRAGILE! Be careful when handling the chamber lamp bulb. It will break if dropped or struck hard against objects.**

- Procedure**
1. Set the main power switch in the OFF position.
 2. Remove the screw from the chamber lamp cover. Use a Phillips screwdriver.

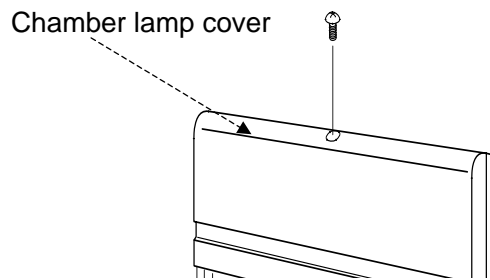

Fig. 8.2 How to detach the chamber lamp cover 1

3. Lift the cover upwards to detach.

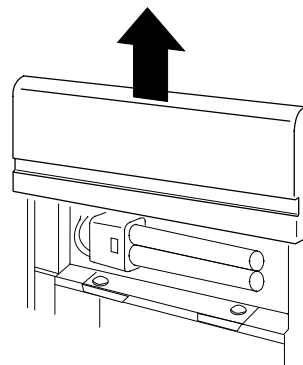

Fig. 8.3 How to detach the chamber lamp cover 2

4. Pull the bulb to the right to detach.

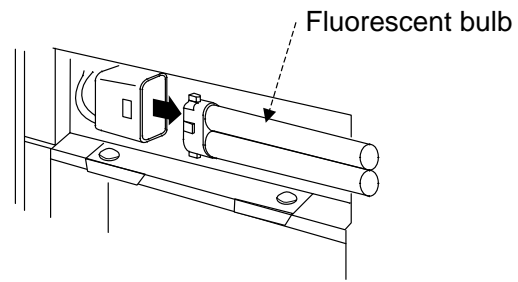

Fig. 8.4 How to detach the chamber lamp bulb

5. Install a new bulb.
6. Reattach the cover and lock it in place with the screw.

Changing the Glow Lamp

Change the glow lamp whenever it blows.

- Procedure**
1. Set the main power switch in the OFF position.
 2. Detach the electric parts compartment door.
 3. Replace the glow lamp with a new one.

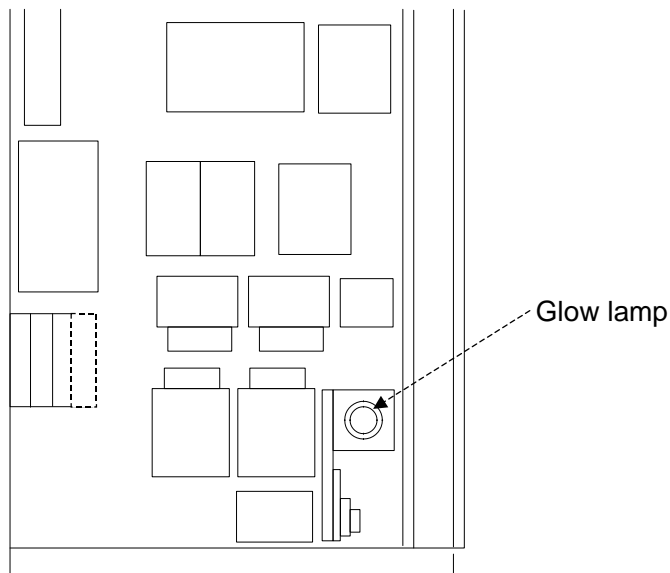

Electric parts chassis (Electric parts compartment)

Fig. 8.5 Glow lamp location

4. Reattach the electric parts compartment door.

Defrosting

 **CAUTION**

- **Defrost the chamber periodically, or too much frost on the cooler causes slow temperature pull-down or remarkably unstable control.**

Do not use the defrosting procedure below in this case. Too much frost on the cooler prevents the defrosting procedure because air does not flow inside the chamber. On the contrary the thermal fuse may blow in order to protect the chamber.

- **In the case of too much frost on the cooler, stop the operation and let the chamber stand at ambient temperature with the chamber door opened for half a day to all day until the frost dissolves.**

- **Be sure to defrost the chamber.**

Frost may form on the cooler in temperature (& humidity) operations below 30 to 40°C.

The refrigerator may be damaged in these continuous operations for a long time.

- If temperature (& humidity) inside the chamber is uncontrollable or rises slowly
- If air blow from the chamber is weak (when the door is opened)
- If frost or ice form on test area walls
- If the "AL-26" alarm is displayed and frost forms on the rear wall of the test area during the temperature and humidity operation

Use this procedure to defrost packing as well.

■ How to defrost chamber

- Procedure**
1. Check the main power switch is in the ON position.
 2. Turn refrigerator control OFF.
For an explanation on how to set refrigerator control, see "5.6 Handy Features".
 3. Change settings so that the operation is not interrupted or an alarm generated if the chamber is run with the door cracked slightly.
Make the following settings. For details on settings, see "Pause control" and "Door Alarm ON/OFF" in "Chapter 6 System Setup" of the User's Manual - Reference -.
 - Turn the pause control OFF.
 - Turn the door alarm OFF.

4. Set target temperature to a minimum 70°C and turn OFF humidity control (not necessary with temperature-only chambers).
5. Press the OPER./STOP key to start the chamber.
Run the chamber for about 60 minutes with the door closed, then for 15 minutes with the door slightly cracked.
6. Return settings made in step 3 to their original settings.

Note | As necessary, drain the humidifying tray manually (not necessary with temperature-only chambers).

