

Quality is more than a word

ESPEC

# Battery Charge/Discharge Test System Integrated with Temperature Chamber

ADVANCED BATTERY TESTER



# Introducing the All-in-One Secondary Battery Charge-Discharge Evaluation System

The Advanced Battery Tester is an entirely new type of charge-discharge test system in which the charge-discharge system and chamber have been designed as a whole. The four functions (performance testing, durability testing, temperature characteristic testing and impedance evaluation), which are essential to maximizing the battery characteristic evaluation functions, are implemented in a single tester.

Patents granted: 7, patents pending: 4

Patents on overall structure and system	<ul style="list-style-type: none"> <li>• Secondary Battery Charge/Discharge Evaluation Equipment (Patent No. 5738660)</li> <li>• Charge/Discharge Test Equipment and Its Manufacture (Patent No. 5558504)</li> </ul>
Patents on the parallel control method	<ul style="list-style-type: none"> <li>• Charge/Discharge Test Equipment, Test Tray, and Charge/Discharge Test System (Patent No. 5769640)</li> <li>• Charge/Discharge Test Equipment (Patent No. 5841042)</li> </ul>
Patent on horizontal air flow control	<ul style="list-style-type: none"> <li>• Environmental Test Equipment (Patent No. 5655040)</li> </ul>
Patent on data sampling	<ul style="list-style-type: none"> <li>• Data Collection Device, Data Collection Method, Program, and Computer-Readable Storage Medium Recording the Program (Patent No. 4855370)</li> </ul>
Patent on the automatic calibration function	<ul style="list-style-type: none"> <li>• Charging/Discharging Power Supply Calibration Device, Charge/Discharge Test Equipment, and Calibration Method (Patent No. 5680014)</li> </ul>

Single-chamber type



Three-chamber type



# Characteristics

## Integration of a Specially Designed Chamber and System Patented in Japan

### ● Integrated design featuring multiple functions

Multiple functions including performance testing, durability testing, temperature characteristic testing and impedance evaluation (tailor-made) are included in this compact tester. A single tester can flexibly meet a wide variety of testing needs.

### ● Cableless design

There are no more bundles of cables passing between the chambers and the power supply system, making the periphery of the tester clean. This design means reduction of time and labor in connecting cables, allowing you to install and start testing quickly. Also this design reduces the voltage drop that occurs due to the wire resistance in cables to a minimum.

### ● Three chambers individual control

The integration of the chambers and the power system in a single structure can control each temperature for each chamber. Also, this system has drastically reduced the footprint than previous system.

### ● Reduced cost of ownership

The elimination of cables has minimized the power supply system loss. This reduces power consumption and also the construction costs for installation. The three-chamber type includes only one refrigerator in each tester. Compared with three chambers of the same size, the cost of ownership can be reduced by up to about 20%. (3-chamber type; Comparison performed by ESPEC)

### ● One call does it all

ESPEC now designs and manufactures the entire tester including the chambers and the power system. In the rare event of a failure, one call to our distributor or our sales staff will take care of you.

### ● Structural drawing

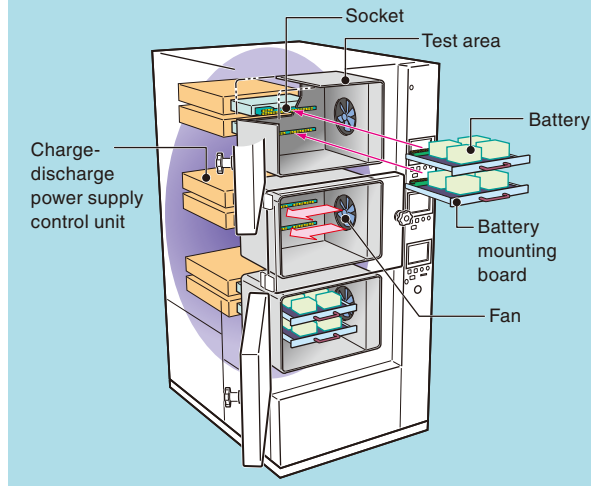

### ● Space saving (Comparison of 3 chamber type)

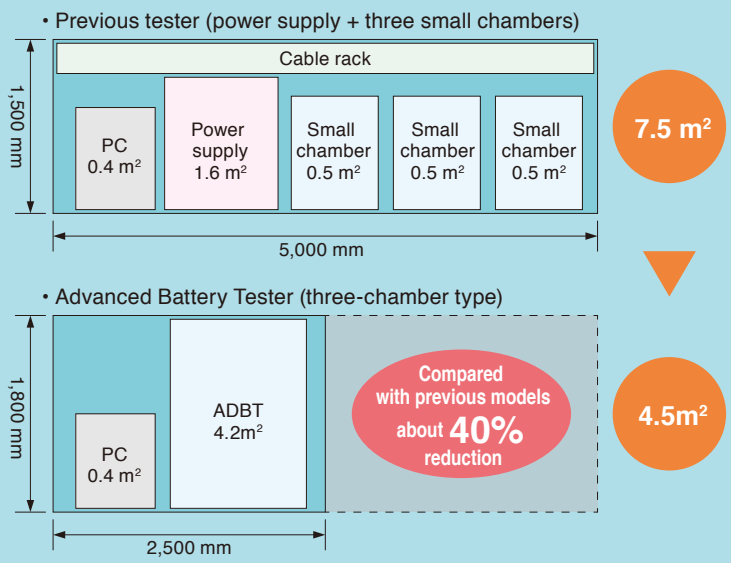

### ● Wiring length vs. voltage drop

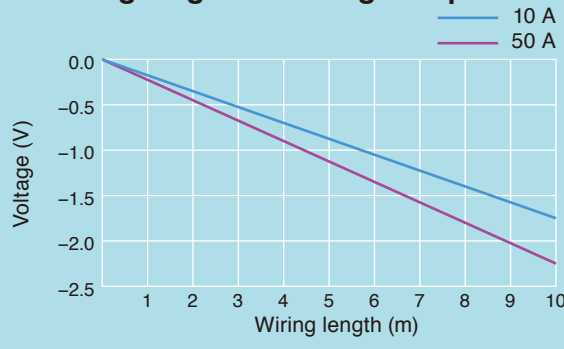

# Characteristics



Three-chamber types



Single-chamber type

## ● Temperature transition comparison

- Previous tester (our temperature and humidity chamber)
- ADBT

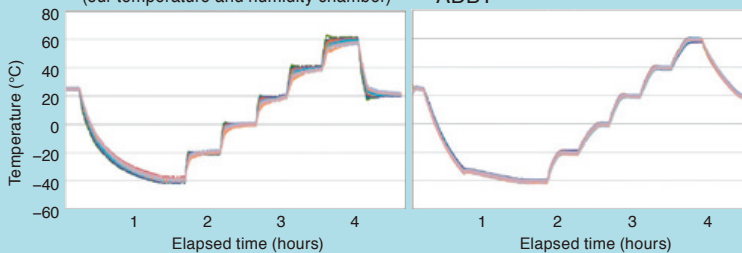

Test conditions:  
 Temperature setting  $-40^{\circ}\text{C} \rightarrow -20^{\circ}\text{C} \rightarrow 0^{\circ}\text{C} \rightarrow +20^{\circ}\text{C} \rightarrow +40^{\circ}\text{C} \rightarrow +60^{\circ}\text{C}$   
 (stable over 30 minutes at each setting)  
 Measurement Install dummy batteries in three shelves in the test area.  
 5 test points in each shelf + 5 test points near the base for a total of 20 test points

## ● Impedance measurement example: Cole-Cole plot (Correlation with temperature)

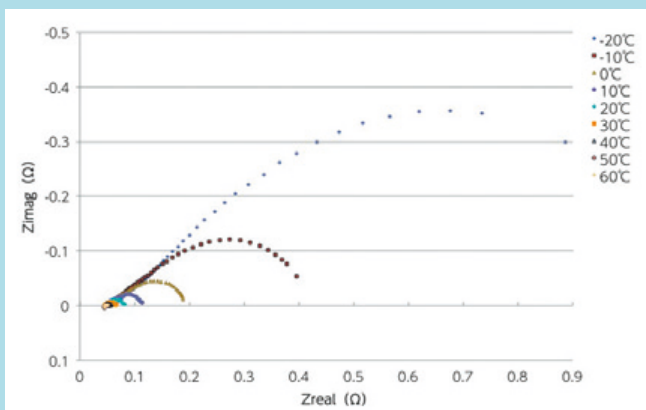

## Chamber

### ● Horizontal air flow

The chambers come with a built-to-engineered rack specifically designed to meet your requirements. This design allows air to flow horizontally even with batteries in place, resulting in better temperature distribution. The air will flow from right to left for the 3 chamber type, and back to front for the single chamber type.

This much improved temperature distribution compared to the conventional flow makes highly repeatable charge-discharge tests possible.

### ● Safety devices (option)

Numerous safety features are available. (Pressure relief vent, CO<sub>2</sub> fire extinguisher, gas detector etc.)

## Power supply system

### ● High accurate time count repeatability

Previous system causes the operation time error for charge-discharge because of its transmission status between PC and power supply board. ADBT system has a 10msec resolution timer inside the system, getting high accurate repeatability of time count without influence of transmission status.

### ● Power supply systems

The voltage range can be covered Max. 6V, The current range can be covered from 1 mA to 1600 A. The parallel operation of the 10 A and 50 A power supply system enables this tester to support high-current tests and high-rate tests. Different types of power supply systems can be mixed in a single tester.

### ● Impedance measurement function (tailor-made)

Impedance can be measured at a specific cycle in a charge-discharge cycle test. Measurements can be taken continuously without removing the batteries, and highly reliable data can be obtained.

# Characteristics

## Battery mounting board

### ● Tailor-made

Custom designs enable support for a wide variety of cell shapes, including coin, laminated, cylindrical, and rectangular cells. The battery shape, orientation, clamp type, quantity, layout and airflow will be considered when designing the board.

### ● Cell temperature measurement

For each channel, the battery mounting board is equipped with a thermocouple for measuring the battery cell temperature. In addition to recording the temperature of each cell, temperature alarms can be set.

### ● Safe and easy test preparation

The tailored board can be detached from the chamber, which enables you to work at a desktop, away from the chamber. This design allows you to prepare for a test in easy three steps:

1. Pull out the board and put it on a table top.
2. Place the batteries.
3. Put the board back on the guide rail and push it back all the way.

In addition, this separate design increase the safety of operators. Whenever the operator places or replaces the batteries, the board will be disconnected from the power supply, eliminating the chance of electrocution.

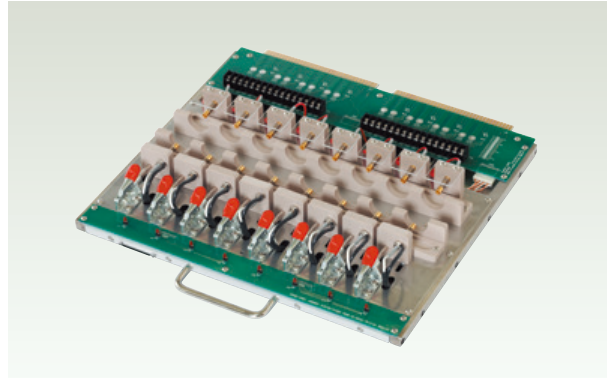

Battery mounting board for cylindrical cells

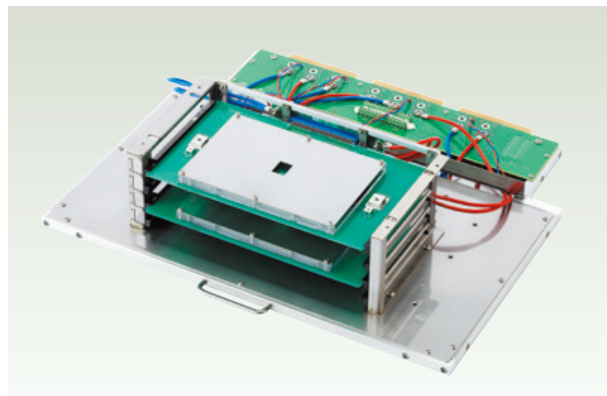

Battery mounting board for laminated cells

## Power supply system calibration

### ● Automatic calibration board (option)

ESPEC provides automatic calibration boards so that you can perform calibration whenever necessary. By simply setting the auto calibration board in place of the battery mounting board, you can easily perform automatic diagnosis and automatic calibration on each channel by selecting the mode on the PC application.

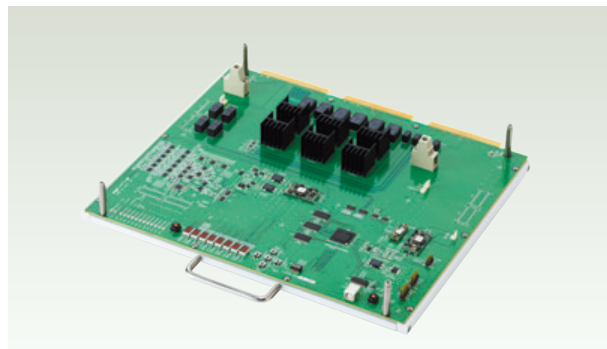

Automatic calibration board

### ● Traceability

The automatic calibration board is traceable to Japanese national standards and calibrated according to ESPEC calibration procedures. Each board is shipped with a traceability system diagram and calibration certificate.

# Characteristics

## ● Test program configuration

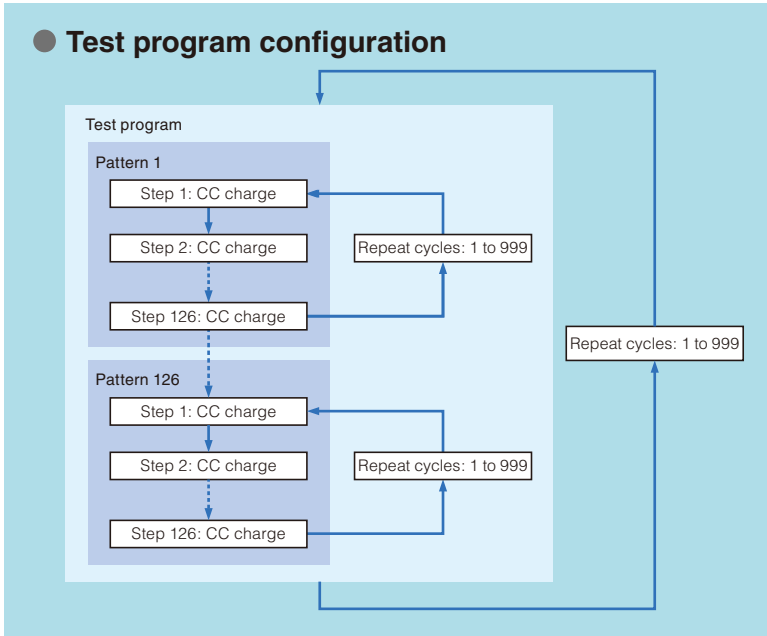

## Software

### ● Test program configuration

The system is standard equipped with charge-discharge test modes (CC charge-discharge, CV charge, CC-CV charge, CP charge-discharge, pulse and standby). You can set the test mode for each step and combine the steps to create a pattern that can be registered. Furthermore, several patterns can be combined to create a wide variety of test conditions. In each step, you can combine various transition conditions including voltage, current and time to specify how to transition to the next step. A test pattern can be looped up to 999 times.

### ● Operation status check

On the main window, the test can be started and stopped while monitoring various types of information, such as the operation status of each channel, test settings, voltage, and current. You can also visually understand the detailed operation status on the status display screen of each channel.

### ● Main window

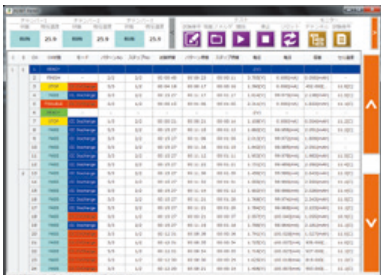

### ● Channel status



### ● Test pattern editing

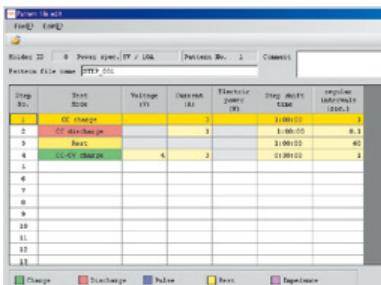

### ● Test step editing

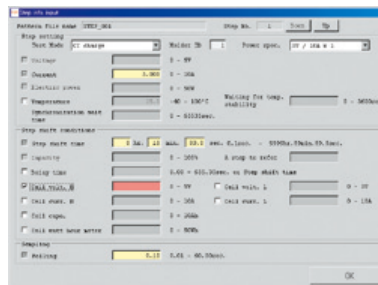

### ● Basic graph

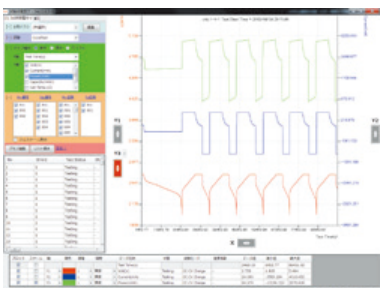

### ● Multiple graph

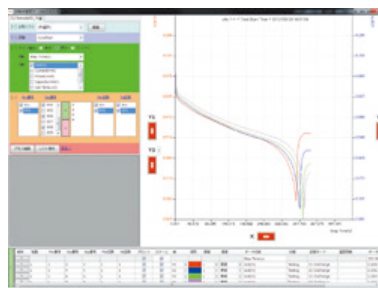

### ● Graph function

The x-axis and y-axis can be set freely, and a secondary y-axis is also available. Superposition of multiple data sets as well as cycle graphs with pattern repetitions assigned to the x-axis are also supported. In addition, a zoom function controlled through the mouse wheel, bitmap exporting of graph images and other data analysis functions are available.

### ● Interlocked test area temperature operation function

A function for synchronizing the chamber and the power supply system is provided as a standard feature. You can specify a temperature setting in a test to synchronize the charge-discharge test with the temperature or perform independently.

# Characteristics

## ● Pulse control

Charge-discharge pulse test profile can easily be programmed by using CSV format.

## ● Touch panel controller (tailor-made)

By using the touch panel controller, you can start, stop and perform other test operations locally. The touch panel screen provides an icon interface. The operator can control test operations through this graphical interface.

## ● IEC 62660-1 test standard support

ADBT system is suitable for IEC 62660-1 test standard for secondary battery cell for electric vehicle.

This test standard requires capacity, power density and energy density measurement and storage life, cycle life and energy efficiency tests.

## Network (tailor-made)

### ● Ethernet connection

From a PC (remote PC) connected to the tester through a LAN, you can monitor the tester status, create test conditions, and view test results data.

You can assign a remote PC as a server PC, connect it to multiple testers, and collectively control the entire system. Test conditions and result data are saved to the server PC's storage. Controller PCs and remote PCs can connect to the server over the network and load test conditions and record results data.

The server PC and remote PCs can be used to perform the same functions as controller PCs except for the tester control operations (setting test conditions; starting, stopping and resuming tests; and controlling chambers).

Furthermore, the tester can be flexibly modified to integrate into the communication network of your host system.

### ● All channel monitoring for touch panel (tailor-made)





### ● Each channel monitoring for touch panel (tailor-made)

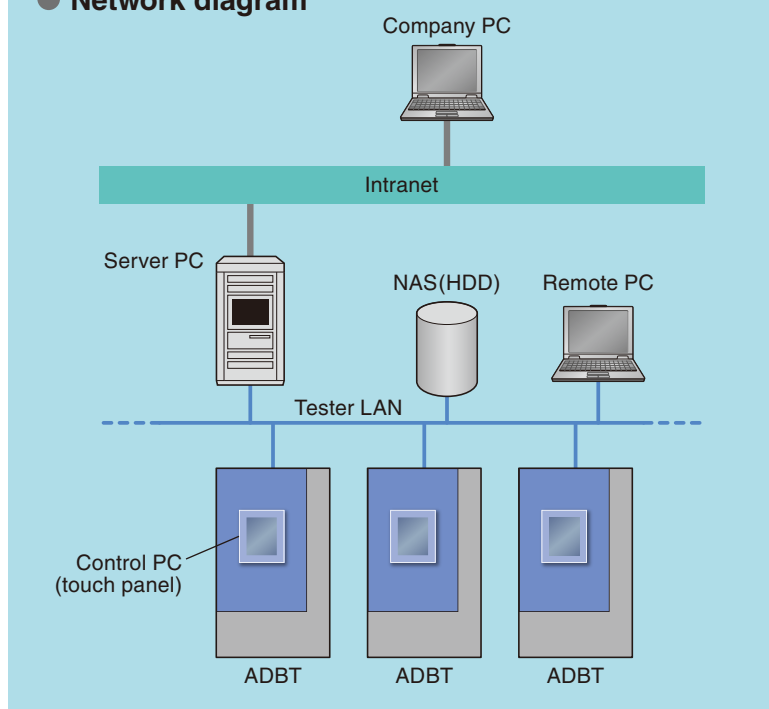

### ● Network diagram

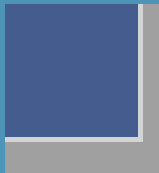
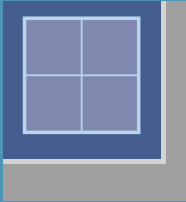

## SYSTEMS

Type			Three-chamber type	Single-chamber type	Wide single-chamber type	Four area-chamber type
						
Interior dimensions (mm)			W 510 H 400 × 3 chambers D 400	W 640 H 850 D 544	W 890 H 850 D 544	W 1130 H 980 D 525
Outside dimensions (mm)			W 950 H 2022 D 1300	W 1250 H 1875 D 1560	W 1750 H 2030 D 1690	W 1590 H 2410 D 1954
Standard	ADBT-5-1	5 V, 1 A	72ch (24ch/chamber)	72ch	—	—
	ADBT-5-10	5 V, 10 A	72ch (24ch/chamber)	72ch	—	—
	ADBT-5-50	5 V, 50 A	24ch (8ch/chamber)	24ch	—	—
High-speed High-current	ADBT-6-400	6 V, 400 A	3ch (1ch/chamber)	contact us	4ch	4ch
	ADBT-6-600	6 V, 600 A	3ch (1ch/chamber)	contact us	contact us	4ch
	ADBT-6-100 to ADBT-6-1600	6 V, 100 A to 6 V, 1600 A	Please contact ESPEC or your dealer regarding chamber combinations.			

\* A parallel connection (for 2-unit and 4-unit operation) is available for 5V, 10A and 5V, 50A testers.

\* Requires separate battery holder for use with parallel connection.

## STANDARD SPECIFICATIONS

Model		Standard			High-speed High-current
		ADBT-5-1	ADBT-5-10	ADBT-5-50	ADBT-6-400
Test area	Control range	-40°C to +100°C			
	Temperature distribution	±1.5°C			
Output voltage	Setting range	0 to 5000 mV (5V)			0 to 6000 mV (6V)
	Output accuracy	±0.1% of F.S.			±0.03% of F.S.
Output current	Setting range	0 to 1 mA 0 to 10 mA 0 to 100 mA 0 to 1000 mA/1 A	0 to 100 mA 0 to 1000 mA/1 A 0 to 10000 mA/10 A	0 to 500 mA 0 to 5000 mA/5 A 0 to 50000 mA/50 A	0 to 50 A 0 to 200 A 0 to 400 A
	Output accuracy	±0.1% of F.S.			±0.03% of F.S.
	Charge-discharge switching time	within 100 msec			within 5 msec
Output power	Setting range	0 to 5 W	0 to 50 W	0 to 250 W	0 to 2000 W
	Output accuracy	±0.2% of F.S.			±0.08% of F.S.
Parallel connection function	2 units	—	16 A	80 A	—
	4 units	—	32 A	160 A	—
Measurement points	Current/Voltage	Current: 1 point per channel / Voltage (specimen edge): 1 point per channel			
	Temperature	1 point per channel		2 points per channel	1 point per channel
Pulse mode	Pulse width (Min.)	1 sec			10 msec
	Number of pulse	5000 pulse			60000 pulse × 2



## SOFTWARE FUNCTIONS

Test condition settings	Structure	Test program: 126 patterns, 999 repetitions max. Pattern: 126 steps, 999 repetitions max.
	Temperature operation	Temperature synchronous operation, temperature asynchronous operation
	Test modes	CC/CV/CC-CV/CP charging, CC/CV/CC-CV/CP discharging, pulse, standby
	Setup items	Measurement range, current, voltage, power, temperature, etc.
	Step transition conditions	Time, current, voltage, power, capacity, etc.
Test operation		Start, stop, force stop (can be executed at the channel level)
Test result display		Detailed data display, graph display (displayed items can be specified), CSV output
Other functions		Test area control, test log, trouble log, operator registration, etc.

## MODEL

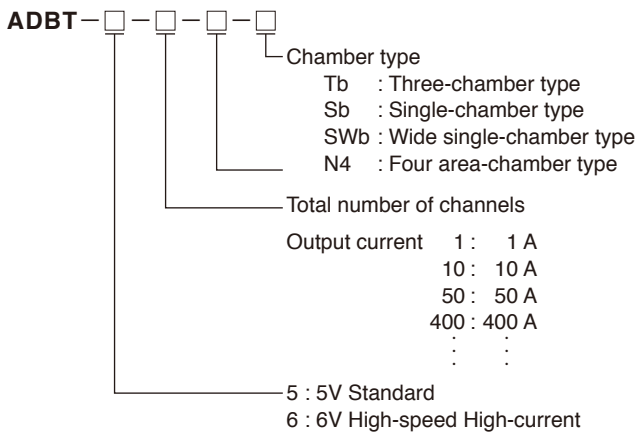

## ACCESSORY

- User's manual (booklet) ..... 1 set
- Host PC set
- Application software  
(pre-installed in host PCs)
- USB cable (for PC and control unit communication)
- Cable port rubber plug (ø50 mm silicon sponge rubber)
- Battery mounting board
- Shipment inspection report ..... 1 set

## SYSTEM CONFIGURATION

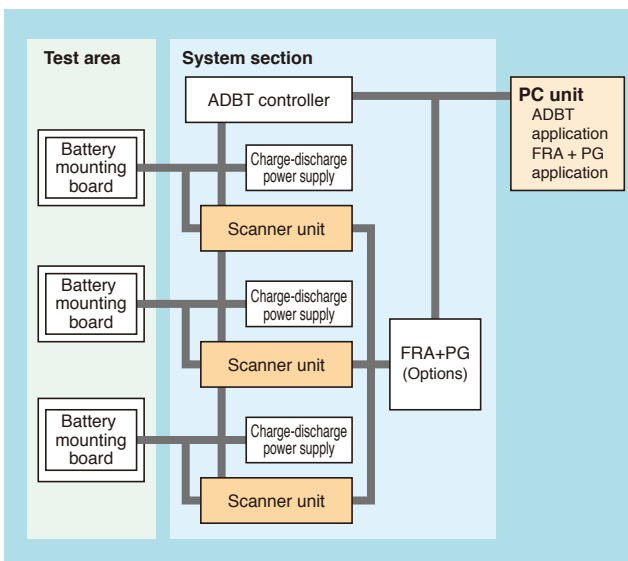

## OPTIONS

### Chamber

#### Pressure relief vent

Releases pressure to reduce explosive power.

Installation location:

Left side: Tb type

Ceiling: types for Sb/SWb/N4

\* The vent does not guarantee safety against explosions.



#### CO<sub>2</sub> fire extinguisher

Starts automatically when a fire (abnormal heat generation) is detected in the test area to extinguish the fire.



#### Safety device triggers

- Heat detector
  - Smoke detector
  - H<sub>2</sub>/CO/H<sub>2</sub>S gas detector
- \* Triggers may be combined.

#### Forced air supply-exhaust mechanism

Reduces the gas concentration in the test area by forcing the air out of the test area. This mechanism can be synchronized with other types of gas detectors.

#### Anchoring fixtures

Used to fix the chamber to the floor.

#### Status indicator light

You can select the light color, whether the light turns on solidly or flashes, and whether to include a buzzer.



#### Power key switch

Used to manage/restrict chamber usage.



#### Automatic calibration board

Enables you to perform automatic diagnosis and automatic calibration at the channel level.

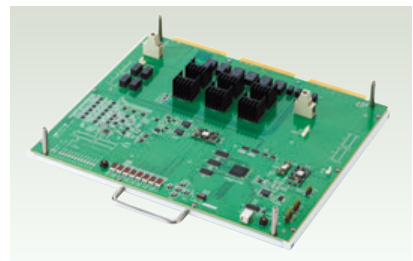

## TAILOR-MADE

### Power supply system

#### 6 V support

6 V power supplies are also available for testing next-generation secondary batteries that cannot be supported at the standard maximum voltage of 5 V.

#### Impedance measurement function

Measures impedance at a specific charge-discharge cycle.

### Battery mounting board

#### Battery mounting board for parallel connection

When the battery mounting board for parallel control is used, the system recognizes its ID and enables parallel control of the power supply systems.

#### Custom battery mounting boards

Dedicated custom battery mounting boards can be provided depending on the cell shape and size that you need.

### Other options

#### Touch panel

By using the touch panel controller, you can test operations locally.



#### Network

A network of multiple Advanced Battery Testers can be constructed.

#### Refrigeration circuit water-cooled system

Changes the condenser of the refrigeration system to water cooling in order to reduce the effect of heat exhaust.

**ESPEC CORP.** <https://www.espec.co.jp/english>

**Head Office**

3-5-6, Tenjinbashi, Kita-ku, Osaka 530-8550, Japan  
Tel: 81-6-6358-4741 Fax: 81-6-6358-5500

**ESPEC NORTH AMERICA, INC.**

Tel: 1-616-896-6100 Fax: 1-616-896-6150

**ESPEC EUROPE GmbH**

Tel: 49-211-361850-0

**ESPEC ENVIRONMENTAL CHAMBERS**

**SALES AND ENGINEERING LTD. STI. (Turkey)**

Tel: 90-212-438-1841 Fax: 90-212-438-1871

**ESPEC ENVIRONMENTAL EQUIPMENT (SHANGHAI) CO., LTD.**

**Head Office**

Tel: 86-21-51036677 Fax: 86-21-63372237

**BEIJING Branch**

Tel: 86-10-64627025 Fax: 86-10-64627036

**GUANGZHOU Branch**

Tel: 86-20-83317826 Fax: 86-20-83317825

**SHENZHEN Branch**

Tel: 86-755-83674422 Fax: 86-755-83674228

**SUZHOU Branch**

Tel: 86-512-68028890 Fax: 86-512-68028860

**TIANJIN Branch**

Tel: 86-22-26210366 Fax: 86-22-26282186

**XI'AN Branch**

Tel: 86-29-88312908 Fax: 86-29-88455957

**CHENGDU Branch**

Tel: 86-28-88457756 Fax: 86-28-88474456

**WUXI Branch**

Tel: 86-510-82735036 Fax: 86-510-82735039

**ESPEC TEST TECHNOLOGY (SHANGHAI) CO., LTD.**

Tel: 86-21-68798008 Fax: 86-21-68798088

**ESPEC ENGINEERING (THAILAND) CO., LTD.**

Tel: 66-3-810-9353 Fax: 66-3-810-9356

**ESPEC ENGINEERING VIETNAM CO., LTD.**

Tel: 84-24-22208811 Fax: 84-24-22208822

**ISO 9001 (JIS Q 9001)**

**Quality Management System Assessed and Registered**

ESPEC CORP. has been assessed by and registered in the Quality Management System based on the International Standard ISO 9001:2015 (JIS Q 9001:2015) through the JSA Solutions Co.,Ltd.

\* The organization of these certificates is  
ESPEC CORP. Japan.



QMS  
JIS Q 9001  
JSAQ 004



MS  
CM001

**ISO 27001 (JIS Q 27001)**

**Quality Management System Assessed and Registered**

\* The organization of these certificates is  
ESPEC CORP. Japan.



ISMS  
JIS Q 27001  
JSAI 165



ISMS-RC  
ISMS ISR006

**ISO 14001 (JIS Q 14001)**

**Environmental Management System Assessed and Registered**

\* The organization of these certificates is  
ESPEC Group Japan.



MS  
CM021

