

5

Daily maintenance and checks

This chapter explains about daily maintenance and checks.

The information herein is very important towards keeping the equipment regularly in proper working order.

5.1 Door lock function (open-close) check

To prevent persons from being trapped inside the chamber, check the door can be opened from both the inside and outside.
Additionally, perform this check every time before someone enters the chamber.

『NOTE』
If the emergency exit device is not tighten enough, door lock cannot operate normally. It may cause trouble of open/close or steam and cooling air leakage. Turn the handle of the emergency exit device to the right direction, and make sure to tighten it.

5.2 Leakage break trip test

This chamber use a leakage breaker as the main power breaker. You need to check the breaker is working properly. Be sure to conduct an operation test of the leakage breaker before starting operation.

[How to check]

Set the [POWER] key on the operating panel in the OFF position and the main power breaker in the ON position.

Then, press the breaker's test button. The breaker should trip instantly and the trip button should pop out. The first thing to do if the breaker does not trip is herein described, is to check the primary power line is properly connected.

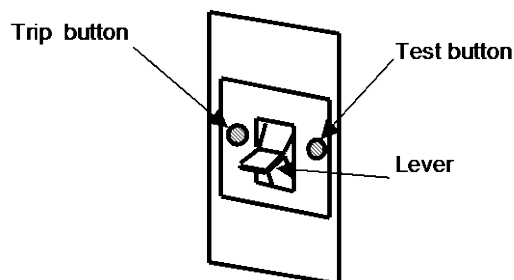

『NOTE』
In the trip test, the breaker lever will stop halfway between ON and OFF (if working properly). To reactivate power, set the switch first to the OFF position and then raise it to the ON position.

5.3 Trip test for the overheat protector

Perform the trip test on the overheat protector before starting chamber tests. The device is located just below the display screen on the operating panel.

『NOTE』

- (1) Set the temperature on the overheat protector to a temperature lower than the inside of the chamber. Set the desired temperature using the Δ (UP) or ∇ (DOWN) key. Press the [UP] or [DOWN] key on the setting screen. The current alarm settings are displayed, and the "A" appears on the display. Set the desired temperature using the [UP] or [DOWN] key. With a key entry of approx. 0.5 seconds, the setting shown on the display is incremented (or decremented) by 1 (one). With a key entry of approx. 2 seconds or longer, the setting shown on the display is incremented (or decremented) by 10 after the lowest digit is reset to 0, if it shows a number other than 0. If no key entry is made (for approx. 5 seconds or longer), the setting is written. After writing of the setting is complete, the display returns to the setting mode screen.

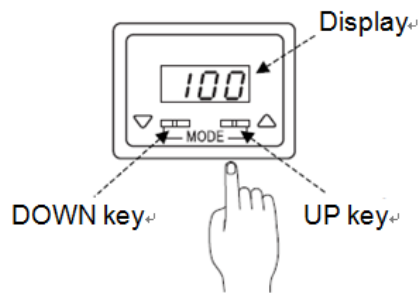

- (2) If the overheat protector is working properly, a buzzer will sound and the Alarm screen will pop up when temperature inside the test area reaches the overheat protector setting. If no alarm triggers, something is wrong with the equipment. Contact the place of purchase or ESPEC CORP.
- (3) To clear the alarm, press [Stop Beep] on the instrumentation screen. When the beeping sound stops, press the power key on the operator panel to turn OFF the instrumentation power supply. Then, return the overheat protector to its usual setting.
- (4) Press the power key to turn ON the instrumentation. Normal status will be restored.

5.4 Test for leakage from water circuit

Check once a day if water is leaking from the water circuit.

Check humidifier water supply circuit, refrigerator cooling water circuit, and connections of the water supply and drainage of the water purifier (option) for looseness or cracks.

The main parts to be checked are as follows:

Humidifier water supply circuit (machine box and area surrounding water supply pipes)

Refrigerator cooling water circuit (machine box and area surrounding water supply and drain pipes)

Area surrounding water purifier (Option)

Area surrounding humidifier drainage pipes

Area surrounding natural drainage pipes

If leakage is discovered, immediately shut off the primary water supply and contact the place of purchase or ESPEC CORP.

『NOTE』

5.5 Humidifier cleaning

As you use the humidifier, scale may accumulate inside the humidifying heater and cylinder. To keep the humidifier in good working order, you need to remove the scale. Clean the humidifier every 3 months as a standard or when “HUM. SCALE BUILDUP WARNING” is displayed on the screen.

Clean the humidifier while the chamber is stopped or running a temperature-only test. If you try cleaning it while a humidity-based test is in course, the “CHECK HUMIDIFIER SWITCH” warning will be generated. In this state, if you then silence the buzzer and attempt to clean the humidifier, do not clear ([CLR] button) the alarm until you finish cleaning. Pressing the [CLR] button in this state will start water supply to the humidifier.

Also, cleaning should be done while the main power breaker is in the ON position. When power is OFF, water inside the humidifier cannot be drained.

[How to clean]

- (1) Set the humidifier ON/OFF switch on the front side of the unit to OFF. This will turn OFF the humidifying heater, start the drain pump and drain the unit.

CAUTION

- The humidifier is HOT shortly after humidity testing. Wait approximately sixty minutes for temperature to drop before cleaning the unit. The steam hose spigot is particularly HOT, therefore cool with a wet towel or other reasonable means.

- (2) Remove the cleaning parts

[In the case of 4kW type]

- ① When ready to proceed, disconnect the steam hose spigot and power line connectors (x2), and remove the winged screws (x6). Then, lift off the top cover together pulling the heater and packing out of the cylinder.
- ② Disconnect the supply and drain hose spigots and remove the cylinder from the humidifier housing.

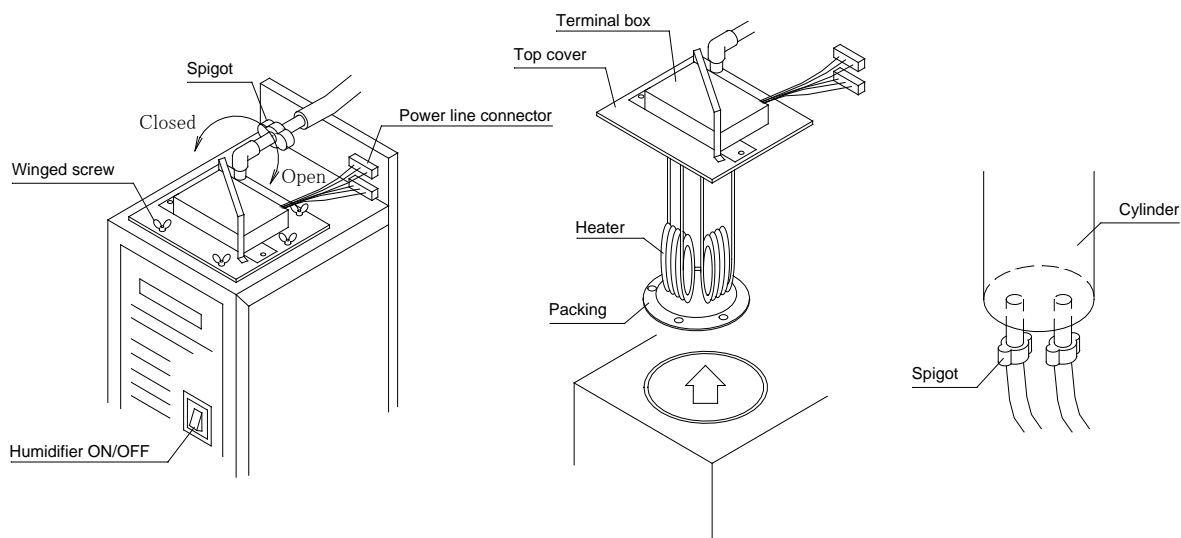

『NOTE』

For humidifier cleaning procedures, see the label attached to the unit and refer to this manual at the same time.

Please be noted cleaning interval for the humidifier can be more often depend upon the quality of water.

[In the case of 6-8kW type]

- ① Remove the winged screw of the hose coupling on the top of the humidifier terminal cover and detach both the steam hose and the coupling.
- ② Remove a humidifier socket, a temperature fuse connector, and two spigots of a cylinder bottom. Lift the main body of a humidifier 4~5cm, and take it out to the front.
- ③ Remove a winged nut and pull out a humidification heater. Clean a humidification heater and a cylinder, respectively.

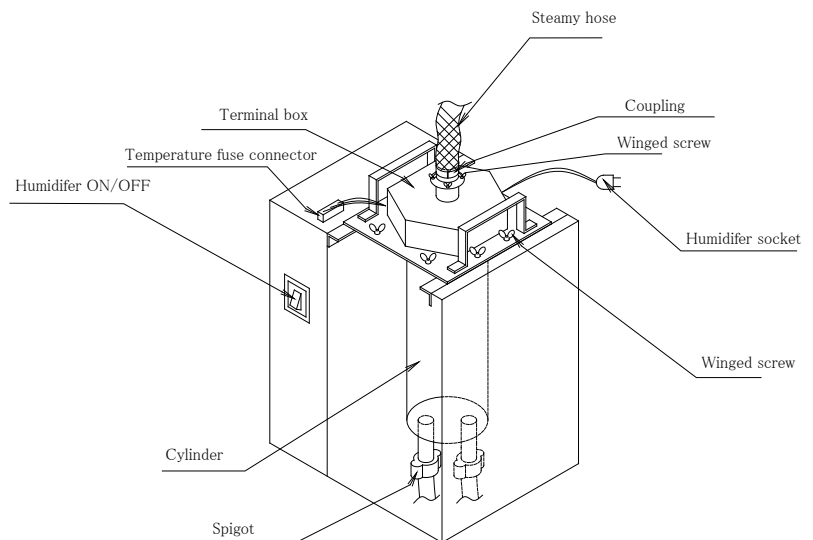

(3) Steam cylinder cleaning

Take the baffle and filters (x2) out of the steam cylinder and remove any scale or foreign matter with a brush or similar means. Unless cleaned of scale, the baffle and filters will block water supply and drainage, so check parts are well-cleaned before reattaching.

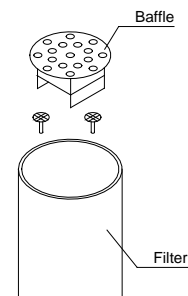

(4) Heater cleaning

If you find scale or foreign matter adhering to the heater element, clean it with a brush or similar means, but be especially careful not to scratch the surface.

CAUTION

- Be careful water does not penetrate inside the heater's terminal box. Penetrating water may cause leakage current when the heater is charged, therefore carefully dry the parts before using again.

(5) Reassembling parts after cleaning

Reassemble parts following steps (1) through (4) in reverse. Securely tighten the top cover of the humidifier to ensure steam and water do not leak. When finished, be sure to set the humidifier ON/OFF switch to ON.

5.6 Humidifying water strainer cleaning

To ensure proper water supply to the humidifier, you need to clean the strainer's filter element every 3 months as a standard or when "HUM. WATER SUPPLY WARNING" is displayed on the screen.

The strainer is at the foot of the humidifier. Clean the strainer while the chamber is stopped or running a temperature-only test. If you try cleaning it while a humidity-based test is in course, the "HUM. WATER SUPPLY ALARM" will be generated.

[How to clean]

- (1) Close the water supply valve.
- (2) Turn by a wrench, take off the cap.
(Water inside pipes will come pouring out, so prepare rags, buckets or similar means as necessary.)
- (3) Remove the element.
- (4) Rinse the element with water.
- (5) After cleaning, reassemble with strainer in its original position. Pay attention to the following when assembling.
 - ① Note that there is forgetting not to put the baffle.
- (6) Open the water supply valve. Make sure water does not leak from the strainer when the valve is opened. Unless reopen the valve, the "HUM. WATER SUPPLY ALARM" will be generated when starting the next humidity test.

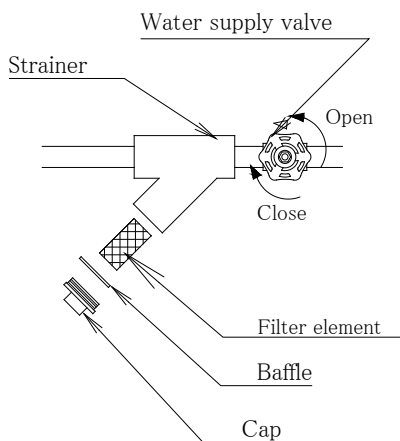

『NOTE』

When the chamber is first installed, foreign matter is trapped inside the line when rigging pipes. The foreign matter will eventually accumulate on the strainer, thus cleaning will be required sooner than expected.

5.7 Mechanical parts compartment filter cleaning (For indoor air-cooled spec.)

Clean dust and dirt from the condenser fin for outdoor refrigerator with a vacuum cleaner or in some other way, once every month.

『NOTE』

Be aware that cleaning cycle for the chamber filter may be shortened, depending on the ambient environment.

5.8 Cleaning of condenser fin (For outdoor air-cooled spec.)

Clean dust and dirt from the mechanical parts compartment filter with a vacuum cleaner or in some other way, once every month as a standard. Make note however that the maintenance cycle will vary according to how clean the air is in the chamber's place of installation.

『NOTE』

Be aware that cleaning cycle for the condenser fin may be shortened, depending on the ambient environment.

5.9 Suction port filter cleaning

You need to clean the air conditioner's suction port filter once every 3 months. During extended use, dust will clog the filter, making it harder for air to circulate.

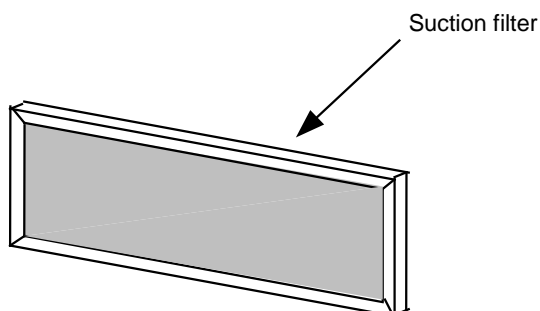

『NOTE』

Be aware that cleaning cycle for the suction port filter may be shortened, depending on the ambient environment.

5.10 Air conditioner drain cleaning

Remove the inlet filter from the bottom of the air conditioner. The water drain is in the middle of the bottom of the air conditioner. As a rule, the drain should be cleaned once every 3 months. Be aware that the water will overflow into the chamber, if the drain becomes clogged.

『NOTE』

Be aware that cleaning cycle for the Air conditioner drain may be shortened, depending on the ambient environment.

5.11 Cooling water strainer cleaning (water-cooled spec. only)

To keep the refrigerator in good working condition, you need to clean the cooling water strainer once every 3 months as a standard. The strainer is located near the refrigerator's cooling water line connection. Clean the strainer while the chamber is stopped. If you try cleaning it while a test is in course, the "REFRIG.: COOLING WATER FAILURE" alarm will be generated.

- (1) Close both the water supply and drain valves (not within ESPEC CORP's sphere of work).
- (2) Using a wrench, take off the strainer's cap.
(Water inside pipes will come pouring out, so prepare rags, buckets or similar means as necessary.)
- (3) Remove the strainer element.
- (4) Rinse the element with water. If ineffective in removing scale, use a wire brush.
- (5) When finished cleaning, reassemble parts as before and be sure to reopen the water supply and drain valves. If you forget to open the valves, the "REFRIG.: COOLING WATER FAILURE" alarm will be generated when starting the next test.

『NOTE』

When the chamber is first installed, foreign matter is trapped inside the line when rigging pipes. The foreign matter will eventually accumulate on the strainer, thus cleaning will be required sooner than expected. Be aware that cleaning cycle for the cooling water strainer element may be shortened, depending on the water quality.

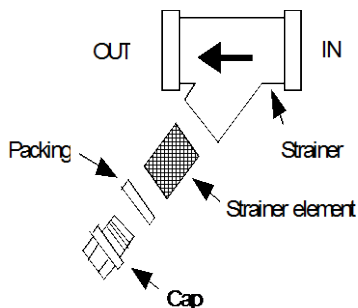

5.12 Changing the wet-bulb wick (For dry/wet-bulb sensor spec.)

The wet-bulb wick is a consumable part of the chamber.

Change it once a month as a standard or before starting long runs.

For equipment manufactured with high-temperature specifications (option), the wet-bulb wick tends to dry after temperature operation of 100°C or higher.

Replace after such operation.

[How to change]

- (1) Pull the wick out of the wet-bulb sensor and set a fresh one. Round the end of the wick and slide it along the wick pan arm until inserted in the wet-bulb sensor. If you accidentally insert the wick into the dry-bulb sensor, temperature and humidity control will be disabled.
- (2) When changing the wick, if you detect scale on the wet-bulb sensor, clean the sensor with a wire brush to keep control from destabilizing later on.

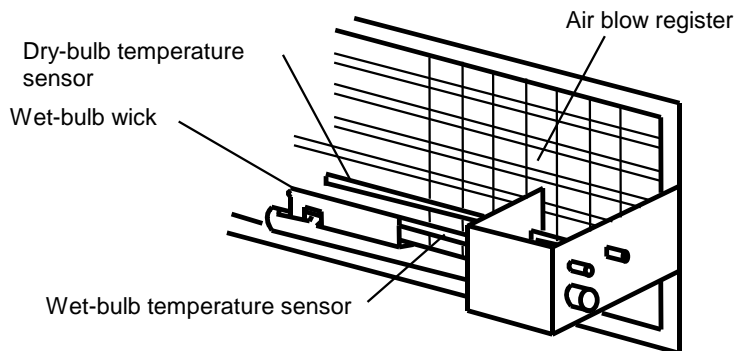

〔NOTE〕

The wick is easily soiled and will require changing sooner than expected if the supplied water is poor quality or if low humidity tests are often run.

If equipped with a water purifier, because chlorine ions are removed, bacteria tends to proliferate and the wet-bulb wick tends to dry. An antibacterial blotter is provided to prevent bacteria from proliferating .

Chambers equipped with a water purifier come also with a antimicrobial blotter to prevent bacteria from proliferating inside the chamber. If the wick dries out quickly, change the blotter and the wick. To do so, roll the blotter up until small enough to fit inside the wick pan arm and insert it inside the arm.

If equipped with a water purifier used as an auxiliary humidifier (ultrasonic humidifier), the wet-bulb wick is not supplied with pure water, so an antibacterial blotter is not provided.

Poor water quality can deteriorate the wick requiring replacement more frequently.

5.13 Wick pan water supplier (container) cleaning (For dry/wet-bulb sensor spec.)

You need to clean the wick pan water supplier once every 3 months as a standard. The water supplier is inside the mechanical parts compartment, towards the top.

[How to clean]

- (1) Remove the winged screw and fill the container with water from the supply line.
- (2) Reattach the winged screw and fill the container with water from the supply line.
- (3) Repeat steps (1) and (2) until clean.

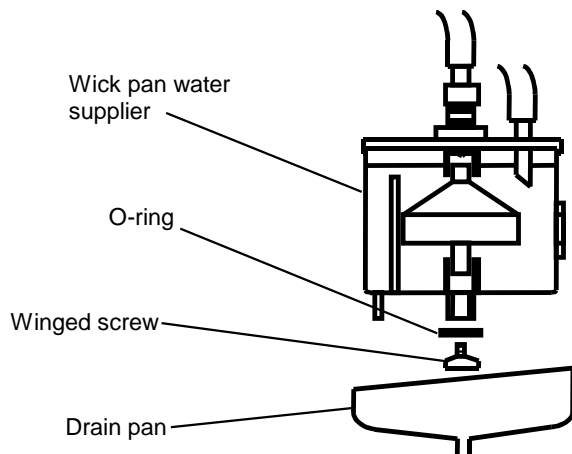

『NOTE』

For the location of the water supplier, see “3.5 Mechanical parts compartment”.

Poor water quality can deteriorate the wick requiring replacement more frequently.

5.14 Check on a light bulb in the chamber

Check if a light bulb runs out or its cover changes in color or cracks (once a month as a standard) or not.

When continuing to use it, there may be accidents such as the deterioration of the brightness uneconomically and the leakage when it ages.

The lifetime of incandescent lamp shall be about a half year and that of fluorescent lamp (option) shall be about 3 to 4 years in case of using 5 to 6 hours a day at around ambient temp. , Although it is different depending on a kind of lamp, temp. (Humid.) Of test condition, lighting time, the number of times or power supply voltage.

In general the life time of lighting fixtures shall be 8 to 10 years when using it at ambient temp. and humid. We recommend you change a light bulb once 5 years in the harsh conditions of the environmental test chamber.



CAUTION

- Tasks involving climbing, such as changing the light bulb in the chamber could result in turning over or falling. Be careful when performing such tasks.

〔NOTE〕

Please contact our distributor or ESPEC CORP. if consumable parts such as incandescent lamp, fluorescent lamp, etc. are not available in your country or region, ESPEC CORP. is not responsible for any accidents or trouble caused by the nonconformance of parts that are not identical to original parts.

The average of life time for incandescent lamp is about 1000hours under the normal temperature condition. It may happen to be fraction of life time depends on the condition of power supply and environmental condition. Generally if 5% higher voltage supplies, the life time is one-half.

The rating life is defined when residual ratio becomes 50%.

In case of incandescent lamp with 1000hors rating life, a half number of lamps lights when several lamps light for 1000 hours.

5.15 Water purifier (ion-exchange type) check and cleaning (Option)

You need to periodically check and clean the water purifier.

Do so according to the cycles specified below and before starting long-runs.

- (1) Cleaning the pressure reducing valve internal strainer (once monthly as a standard).

Close the main valve of the water supply. Remove the strainer cap with a wrench. (Have a cloth and a wash bowl, etc. ready to catch any water that drips from the pipe.)

Take out the internal strainer element and wash it with water.

- (2) Checking operation of safety valves and pressure (once every 3 months).

Pull the operation lever of the safety valve and check the water flows in output piping of the safety valve clear tube. Then put back the operation lever and check that the pressure gauge shows under 0.08 MPa (Gauge) [under approx. 0.8kg/cm²G].

『NOTE』

When the chamber is first installed, foreign matter is trapped inside the line when rigging pipes. The foreign matter will eventually accumulate on the strainer, thus cleaning will be required sooner than expected. Be aware that cleaning cycle for the internal strainer element water strainer filament may be shortened, depending on the water quality.

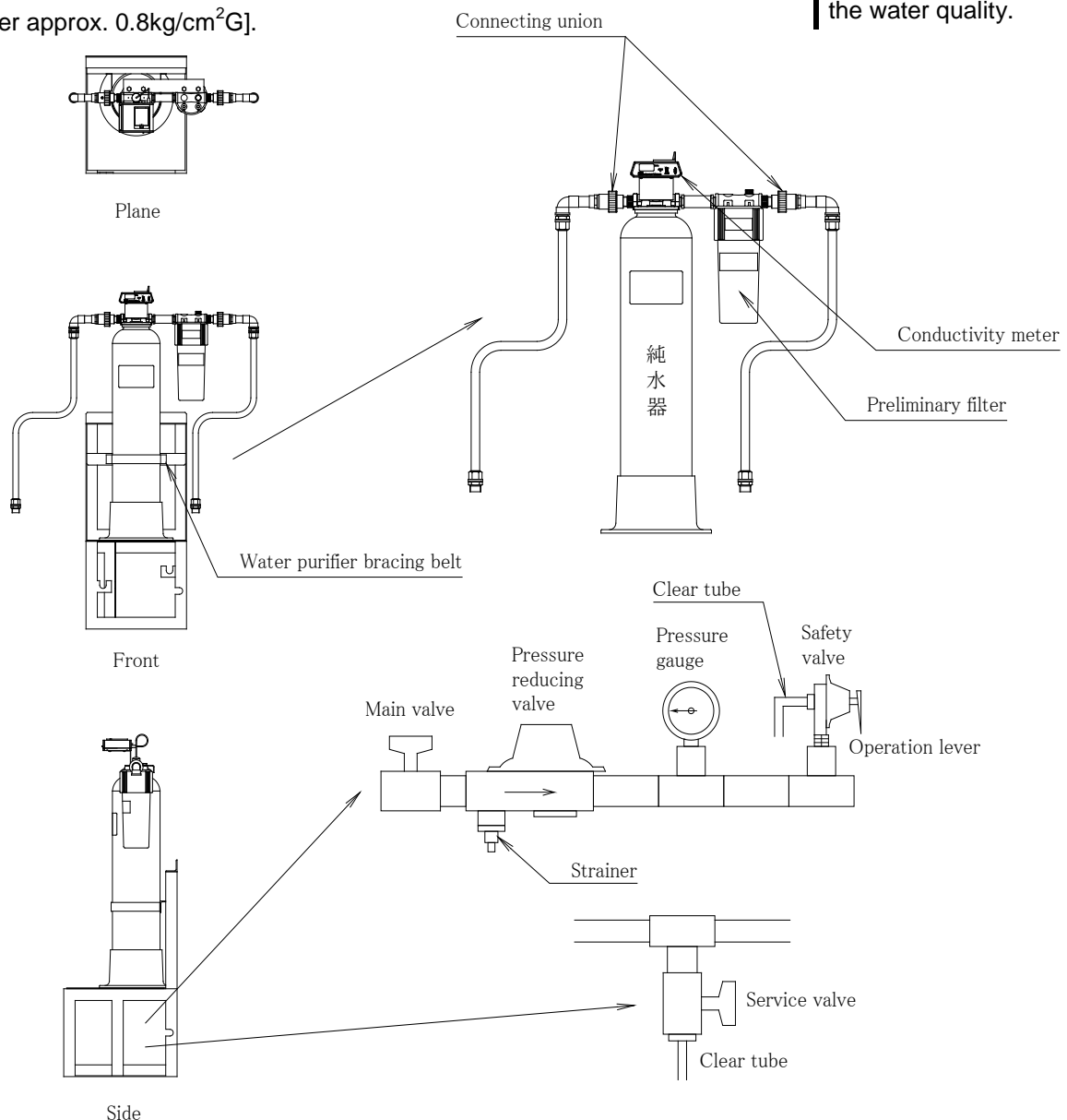

(3) Checking water quality (Once monthly)

Set the switch of the conductivity meter on the top of water purifier unit in the MEAS position to check if conductivity is lower than 10.0 $\mu\text{S}/\text{cm}$.

Note that if the water purifier is not used for a long time, conductivity can become high. Measurement should therefore be taken again after about 50cm³ of water has been drained from the service valve on the lower part of the water purifying unit.

※ The conductivity meter's indication shows "OFF" when the switch is not in the MEAS position. This isn't error.

(4) Changing the water purifier

When the conductivity in section (3) is above 10.0 $\mu\text{S}/\text{cm}$, the useful life of the ion exchange resin is at its end and therefore the water purifier should be changed.

1. Close the main valve of the water supply.
2. Lift the safety valve operating lever, and reduce the pressure inside the pipe to nearly 0MPa (Gauge). (Once the pressure is reduced, put the operating lever back to its original position.)
3. Remove the connecting unions at the inlet and outlet of the water purifier. (Prevent splashing of water still remaining in the hose by wrapping a piece of cloth around each union.)
4. Remove the water purifier bracing belt. (Attached by screw.)
5. Replace the water purifier with a new unit.
6. Attach the water purifier bracing belt to secure the water purifier.
7. Fit the connectors.
(Connect the connector securely at both inlet and outlet.)
8. Open the water supply valve.
(Remove the water purifier and the air inside the hose from the service valve.)
9. Check to make certain that there is no water leak.

『NOTE』

when conductivity is above 2.0 $\mu\text{S}/\text{cm}$ the useful life of the water is near its end and therefore the inspection cycle should be kept short.

(Once every 2 weeks)

It becomes more than 10.0 $\mu\text{S}/\text{cm}$ after 2000 hours-operation at 30°C/80% without specimen, but please understand this will be changed depending on the operation condition. When the water supply conductivity is 200 $\mu\text{S}/\text{cm}$,

G-10 :

Approx. 1900 liters

G-20 :

Approx. 3800 liters
can be extra-cted.

The length of the cycle varies according to the quality (amount of iron particles etc.) of the primary water supply.

Weight of the water purifier

G-10: Approx. 20kg

G-20: Approx. 40kg

Please exercise caution when transferring the water purifier.

(5) Changing the preliminary filter

1. Close the main valve of the water supply.
2. Lift the safety valve operating lever, and reduce the pressure inside the pipe to nearly 0MPa (Gauge). (Once the pressure is reduced, put the operating lever back to its original position.)
3. Remove the filter cap by hand by turning it a little at a time. (Take care not let any water leak from inside the cap.)
4. Change the inside filter (5 μ m) .
5. Put the filter cap on.
6. Open the water supply valve.
7. Check to make certain that there is no water leak.

『NOTE』

The ion exchange resin of the water purifier is recyclable. Send the unit back to the manufacturer when no longer necessary. Ship it in its original container, therefore conserve packaging materials.

As a guide, exchange preliminary filter on the same basis with water purifier exchange.

5.16 Dehumidifier check and cleaning (Option)

You need to periodically check and clean the dehumidifier. Do so according to the cycles specified below and before starting long-runs.

(1) Suction port filter cleaning (Once monthly as a standard)

Remove the filter from the air intake port and rinse with water. During extended use, dust will clog the filter, making it harder for air to circulate and may trip the overheat protector on the recycling circuit intake.

『NOTE』

Please be noted cleaning interval for the filter of dehumidifier can be more often depend upon the surrounding conditions.

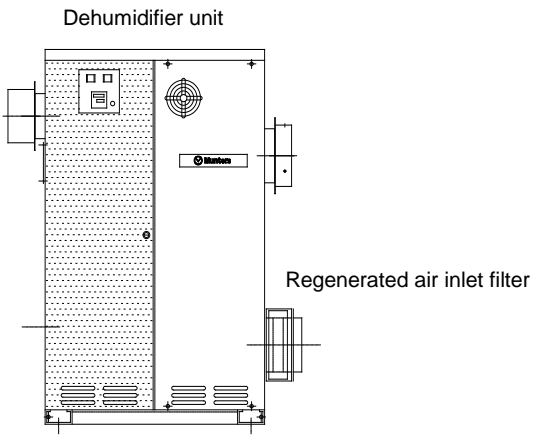
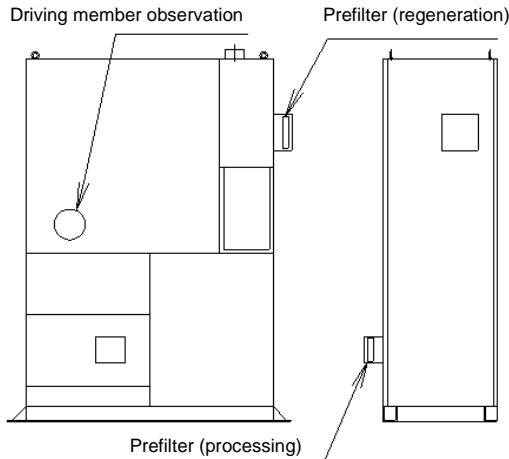
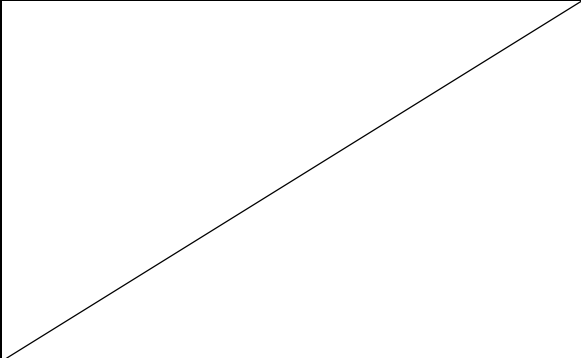
BX series	ESP series
 <p>Dehumidifier unit</p> <p>Regenerated air inlet filter</p>	 <p>Driving member observation</p> <p>Prefilter (regeneration)</p> <p>Prefilter (processing)</p>
	<p>Checking of the rotation of the dehumidification rotor (Once in six months)</p> <p>While the dehumidifier is in operation, check whether or not the rotor inside is rotating smoothly by a visual inspection through the observation hatch of the driving member.</p> <p>The rotor is rotating at a low speed (less than several tens of revolutions per hour) by chains and sprockets.</p>

5.17 Humidity sensor calibration (Option)

We recommend the humidity sensor be calibrated once a year to maintain its accuracy in taking measurements. Contact ESPEC CORP. to have your humidity sensor calibrated.

『NOTE』