

## 8.2 Before You Call for Service

 <b style="font-size: 1.2em; margin-left: 10px;">DANGER</b>
<ul style="list-style-type: none"> <li> <p>• <b>ELECTRIC SHOCK!</b> Before working on the power circuits on the primary side of the main power switch (leakage breaker), shut OFF primary power supply and check the line is dead. Also, take measures to prevent accidental charging. Working with primary power supply ON runs the risk of electric shock.</p> </li> <li> <p>• <b>Shut OFF power from the main power switch (leakage breaker) BEFORE detaching the electric parts compartment door.</b></p> </li> </ul>

This section explains troubles undetected in chamber self-checks and cases of misoperation which are easily mistaken as trouble. If the trouble cannot be remedied after taking the prescribed action, contact the place of purchase or ESPEC CORP.

Table 8.2 Before you call for service

Trouble	Cause	Remedial action
The instrumentation panel does not light up after pressing the <span style="border: 1px solid black; padding: 2px;">POWER</span> key.	Primary power supply is OFF.	Activate the primary power supply.
	The main power switch is in the OFF position.	Set the main power switch in the ON position.
	The electric parts compartment door is open.	Close the door.
	There is a reverse or open phase in the primary power supply connection.	Reconnect the primary power supply correctly. See "4.2 Drainage & Power Supply Work".
	Fuse F1 is blown.	Replace fuse F1. See "8.3 User Practical Servicing". If the new fuse blows, call for service.
The display goes out all of sudden or the displayed information is strange.	System trouble or internal board trouble	Switch the main power switch OFF and ON. If the same trouble reoccurs, call for service.
The door is hard to close.	Something is caught in the door.	Remove the obstruction.
	Frost has formed and hardened on the door packing.	Defrost the chamber. See "8.3 User Practical Servicing".
	The chamber is hot on the inside, so internal pressure is high.	There is nothing wrong with the equipment. Proceed as planned.

Cont.

<b>Trouble</b>	<b>Cause</b>	<b>Remedial action</b>
The door is hard to open.	Internal pressure is lower than room pressure.	There is nothing wrong with the equipment. Proceed as planned.
The door is hard to open/close.	Internal pressure is lower than room pressure.	There is nothing wrong with the equipment. Proceed as planned.
	Frost has formed and hardened on the packing.	Defrost the chamber. See "8.3 User Practical Servicing".
Strange odors are detected.	Lingering odors inside the chamber	Clean the test area. See "7.3 Maintenance".
	Specimens are generated odors.	Remove the source of the odor.
The chamber is vibrating.	Adjuster feet are not the proper height. (For caster-equipped chambers only. Casters are optional.)	Correct adjuster foot height. See "4.1 Installation".
The viewing window is clouded or frosted over.	Moisture inside the chamber evaporated as temperature rose rapidly, whereby driving up humidity.	There is nothing wrong with the equipment. Proceed as planned.
	The fuse in the frost prevention heater blew.	Replace fuse F2. See "8.3 User Practical Servicing".
The chamber is wet on the outside.	The room is highly humid.	There is nothing wrong with the equipment. Proceed as planned.
Frost has formed on door hinges and around the door frame and viewing window.	The room is highly humid.	There is nothing wrong with the equipment. Proceed as planned.
	Fuse F2 is blown.	Replace fuse F2. See "8.3 User Practical Servicing". If the new fuse blows, call for service.
Temperature is unstable.	The door is open.	Shut the door.
	The cable port rubber plug fell off.	Fit the cable port rubber plug.
	Ambient temperature changes more than 5°C/h.	Stabilize ambient temperature and resume testing.
	High heat load equipment is being turned ON/OFF.	Reduce the heat load.
Temperature gradually rises higher than the target temperature.	Specimens are generating heat.	Reduce the amount of heat generated by specimens.
	Frost has formed on the cooler.	Defrost the chamber. See "8.3 User Practical Servicing".
Settings cannot be changed.	The keys are locked.	Unlock the keys.
Temperature heat-up/pull-down rate does not satisfy specifications.	The door is open.	Shut the door.
	Specimens are generating heat.	Reduce the amount of heat generated by specimens.
	Ambient temperature too low (high).	Raise (Lower) ambient temperature.
Temperature stops rising or begins to drop during heat-up.	Frost has formed on the cooler.	There is nothing wrong with the equipment. Proceed as planned or defrost the chamber. See "8.3 User Practical Servicing".

Cont.

Trouble	Cause	Remedial action
Poor temperature uniformity	Air flow inside the chamber is poor.	Rearrange specimens so as not block air flow.
	Specimens are generating heat.	Reduce quantity of specimens.
	Frost has formed on the cooler.	Defrost the chamber. See "8.3 User Practical Servicing".
	Outside air is penetrating through door packing or the cable port.	Prevent air penetration.
The chamber lamp does not light.	The fuse is blown.	Replace fuse F2. If the new fuse blows immediately, call for service. See "8.3 User Practical Servicing".
	The bulb is blown.	Replace the bulb. See "8.3 User Practical Servicing".

---

## 8.3 User Practical Servicing

---

### Replacing Fuses

When a fuse blows, replace it with one of the included fuses (250V AC 3A).

**Note** If a new fuse blows soon after being installed, contact the place of purchase or ESPEC CORP.

- Procedure**
1. Shut OFF primary power supply to the chamber.
  2. Set the main power switch in the OFF position.
  3. Remove the two screws on the top of the electric parts compartment door and detach the door. This will require a Phillips screwdriver.
  4. Replace the blown fuse with a new one.

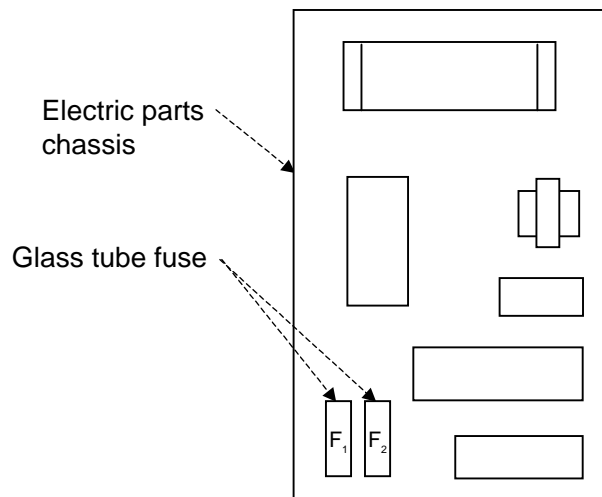

Left edge of electric parts chassis (Electric parts compartment)

Fig. 8.1 Fuse location

5. Reattach the electric parts compartment door.

## Replacing the Chamber Lamp Bulb

Replace the chamber lamp bulb once a year or whenever it blows, with the included 24V AC, 5 W bulb. Work will require a Phillips screwdriver.

 **CAUTION**

- **HOT! The chamber lamp bulb is hot immediately after it goes out. Be careful not to burn yourself.**
- **The chamber lamp bulb will break if dropped. Be careful when handling.**

- Procedure**
1. Set the main power switch in the OFF position.
  2. Remove the screw that locks the cover to the viewing window. This will require a Phillips screwdriver.

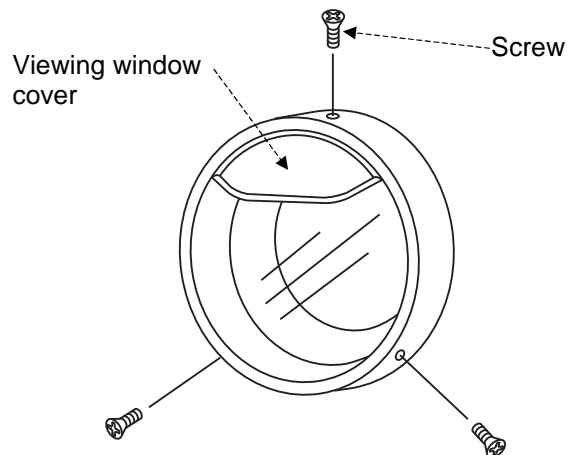

Fig. 8.2 Detaching the viewing window cover

3. Detach the viewing window cover.
4. Press the bulb inward in its holder and turn to the left to remove.

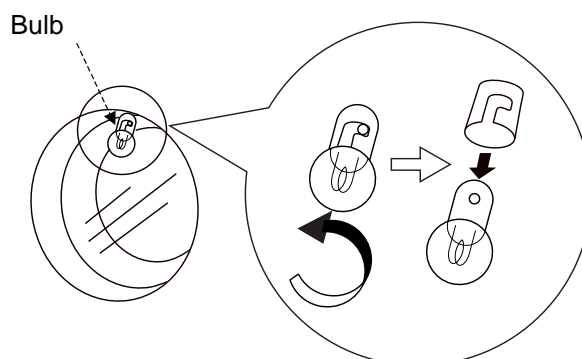

Fig. 8.3 Removing the chamber lamp bulb

5. Insert a new bulb.
6. Reattach the viewing window cover and lock in place with the screw.

## Defrosting

### CAUTION

- **Defrost the chamber periodically, or too much frost on the cooler causes slow temperature pull-down or remarkably unstable control.**

Do not use the defrosting procedure below in this case. Too much frost on the cooler prevents the defrosting procedure because air does not flow inside the chamber. On the contrary the thermal fuse may blow in order to protect the chamber.

- **In the case of too much frost on the cooler, stop the operation and let the chamber stand at ambient temperature with the chamber door opened for half a day to all day until the frost dissolves.**

- **Be sure to defrost the chamber. Frost may form on the cooler in temperature (& humidity) operations below 30 to 40°C.**

The refrigerator may be damaged in these continuous operations for a long time.

- If temperature inside the chamber is uncontrollable or rises slowly
- If frost or ice form on test area walls
- If frost or ice form on the viewing window on the inside

Use this procedure to defrost packing as well.

#### ■ How to defrost chamber

##### Procedure

1. Check the main power switch is in the ON position.
2. Set target temperature to 70 to 80°C from within the constant mode.
3. Turn refrigerator capacity control OFF.  
For an explanation on how to set refrigerator control, see "5.3 Target Temperature Setup".
4. Get the Operation Mode Selection screen.  
Press the **OPER./STOP** key on the operating panel or the chamber operating status box on the screen to start the chamber.
5. Press the **START** button under Constant Mode to start the chamber.  
Run the chamber for about 60 minutes with the door closed, then for 15 minutes with the door slightly cracked.

