

For power semiconductor

FET/IGBT Power Cycle Test System

Model: RBS-A1-1010 43RL

Reference Power devices
<http://www.espec.co.jp/english/products/market/auto/power.html>
<http://www.espec.co.jp/english/products/market/new/power.html>



FET/IGBT power cycle test system does the feedback control of various parameters for the device such as Power MOSFET and IGBT while monitoring temperature (T_j) of the device. The system will monitor and data logging of Junction temperature (T_j), Quantity of cooling water flow, stress voltage, and current to the device. This device consists with cooling plate, instrument rack, chiller unit, and the personal computer with Windows.

Targeted device

Power semiconductor

Power MOS FET is widely used as an electric power control device in the electronics equipment. With using latest LSI technology, it contributes to miniaturizing and making higher efficiency as a high-speed switching element with low on resistance. The IGBT module is a semiconductor switching element used to control the high-power for the inverter and the DC-DC converter. Although the switching speed is same as Power MOSFET of the same rating voltage, it's small on resistance attracts attention as a semiconductor for electric vehicle (EV).

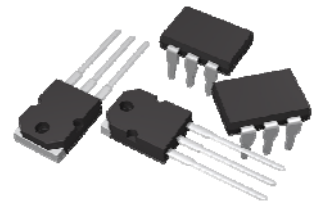

Power MOS FET

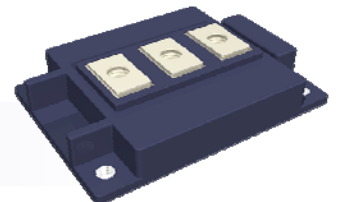

The IGBT module

Feature and Application

The device cooling method is the water-cooled cooling plate method

T_j temperature control of the high heat dissipating device can be done at high accuracy of $\pm 1^\circ\text{C}$.

Device is cooled by the controlled constant temperature cooling water from the chiller circulating at the waterway in the cooling plate. For the IGBT module, each module has individual waterway and the flow of cooling water will be controlled individually. Maximum dissipated heat up to 6kW can be handled.

The water temperature can be set within the range of -10 to $+10^\circ\text{C}$ at low temperature side and $+60$ to $+80^\circ\text{C}$ at high temperature side.

Applicable to various test standards.

The constant current control An impressed current to the device is monitored and fed back to the V1 voltage to control impressed current within designated range. The V1 voltage is controlled high and low corresponding to the comparison between monitored current value against with set value for continuous mode and cycle modes. Under Cycle mode, the maximum current monitored will be reflected as a limit for next cycle. It terminates the test when Vec voltage reach the set value of each Low and High boundary.

The fixed T_j control It monitors the T_j temperature (conversion from the temperature monitor voltage) and fed them back to Cooling water flow control and V1 voltage control to maintain T_j temperature within the designated range. When T_j temperature reaches the management limit, the test will be stopped.



Cooling plate

System Block Diagram

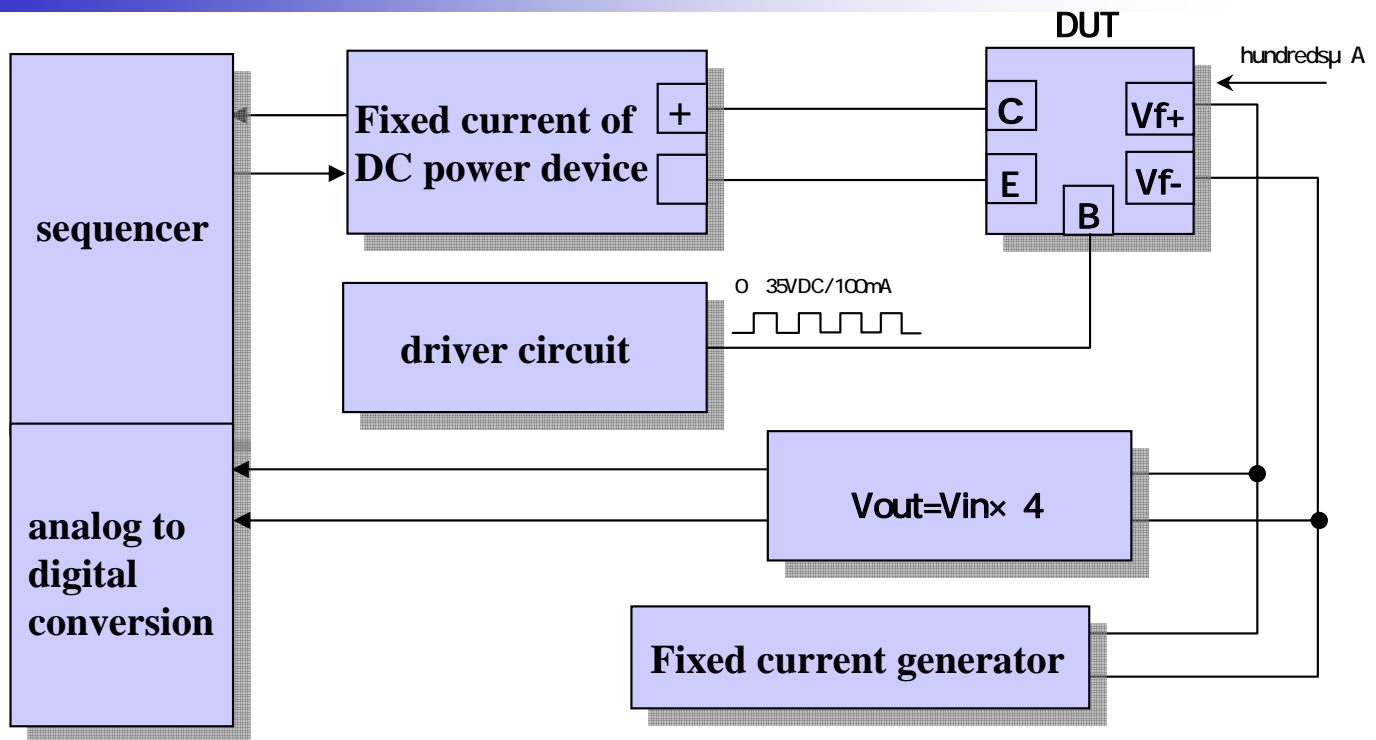

Specifications

No.	Name	Number of CH	Sampling	Size	Size measurement accuracy	remarks
1	DUT temperature		100msec	3V or less 3.3mV/	± 1.5	
2	Voltage between main power supply terminals Vds		100msec	3V or less	± 15mV	
3	Flowing quantity of DUT cooling water		100msec	1cc/PLS		
4	Gate voltage		100msec	30V or less	± 0.5V	A set voltage is displayed.
5	Main circuit current		It updates it at one cycle of the second.	1000A 6units	± 10A	Current output in power supply
6	hiller exit supply water temperature		It updates it at one cycle of the second.	100 +100	± 3	Temperature detection edge
7	Cycle number		GATE ON/OFF cycle	100 million times		59 million 994 thousand times at the ON/OFF=0.3/0.3 second.

Reference Power devices <http://www.espec.co.jp/english/products/market/auto/power.html>
<http://www.espec.co.jp/english/products/market/new/power.html>



If you have any questions or your request, please contact to our customer center.
<http://www.espec-global.com/>

<http://www.espec.co.jp/english/index.html>



Digital Consumer Electronics



- [_LCD/PDP](http://www.espec.co.jp/english/products/market/da/pdp.html)
- [_PCB](http://www.espec.co.jp/english/products/market/da/print.html)
- [_Secondary battery](http://www.espec.co.jp/english/products/market/da/secondbattery.html)
- [_Digital camera](http://www.espec.co.jp/english/products/market/da/digicame.html)
- [_DVD/HDD/Storage](http://www.espec.co.jp/english/products/market/da/dvd.html)
- [_Semiconductor](http://www.espec.co.jp/english/products/market/da/semicon.html)
- [_LED](http://www.espec.co.jp/english/products/market/da/daled.html)
- [_Printer / Copier](http://www.espec.co.jp/english/products/market/da/ppc.html)

Information Technology



- [_Optical module/Optical devices](http://www.espec.co.jp/english/products/market/it/light.html)
- [_Semiconductor](http://www.espec.co.jp/english/products/market/it/semicon.html)
- [_Capacitors](http://www.espec.co.jp/english/products/market/it/condensor.html)
- [_Secondary battery](http://www.espec.co.jp/english/products/market/it/secondbattery.html)
- [_Mobile phones](http://www.espec.co.jp/english/products/market/it/mobile.html)
- [_Personal computers](http://www.espec.co.jp/english/products/market/it/pc.html)
- [_PCB](http://www.espec.co.jp/english/products/market/it/print.html)

Automobile



- [_In-vehicle sensors](http://www.espec.co.jp/english/products/market/auto/sensor.html)
- [_LED](http://www.espec.co.jp/english/products/market/auto/autoled.html)
- [_Secondary battery](http://www.espec.co.jp/english/products/market/auto/secondbattery.html)
- [_CCD](http://www.espec.co.jp/english/products/market/auto/ccd.html)
- [_Power devices](http://www.espec.co.jp/english/products/market/auto/power.html)
- [_Car navigation system](http://www.espec.co.jp/english/products/market/auto/carnavi.html)
- [_ECU](http://www.espec.co.jp/english/products/market/auto/ecu.html)
- [_Semiconductor](http://www.espec.co.jp/english/products/market/auto/semicon.html)
- [_PCB](http://www.espec.co.jp/english/products/market/auto/print.html)

New Energy



- [_Fuel cell](http://www.espec.co.jp/english/products/market/new/fuelbattery.html)
- [_Solar battery](http://www.espec.co.jp/english/products/market/new/solarbattery.html)
- [_Power devices](http://www.espec.co.jp/english/products/market/new/power.html)
- [_Secondary battery](http://www.espec.co.jp/english/products/market/new/secondbattery.html)