

Quality is more than a word

ESPEC

Thermal Shock Chamber

TSE-11-A



ESPEC offers a compact, but highly performant thermal shock chamber ideal for the requirements of test standards with small and low-volume specimen.

Equipped with superior temperature recovery performance capable of answering the requirements of severe test specifications, this thermal shock model offers a wide test area in a compact, slim design.



Characteristics

A high performance compact package to meet severe test requirements.

- **A temperature recovery time of less than 5 minutes is achieved in 2 zones (+150°C and -65°C) without auxiliary cooling**

By realizing a temperature recovery time of less than 5 minutes for the upstream air in the 2 zones (+150°C and -65°C), we have achieved performance equivalent to that of a large thermal shock chamber without having to use auxiliary cooling by means of liquid carbon dioxide, which was required in previous compact thermal shock chamber.

- **Complies with MIL-STD-883H and other test standards**

This compact thermal shock chamber satisfies the temperature cycle test requirements of MIL-STD-883H and other test standard (see page 5).

- **Smooth specimen transfer**

The "soft-move mode" is used to reduce vibration shock when specimens are moving between the hot and cold chambers.

- **Uniform temperature distribution across specimens**

High temperature uniformity performance ensures consistent stress on specimens.

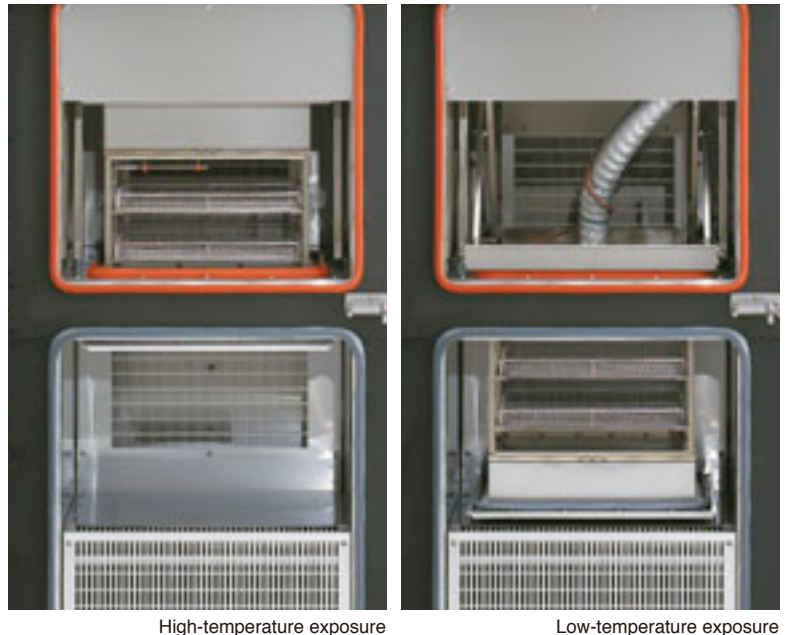

● Examples of temperature uniformity

• Test conditions

High temperature exposure + 150°C 30 min.
Low temperature exposure - 65°C 30 min.
Specimen Plastic molded IC 2kg

• Temperature uniformity measurement method

Thermocouples were embedded in 10 plastic molded ICs (16 pin DIPs), which were then placed on two levels in each of the corners and in the center of a specimen basket.

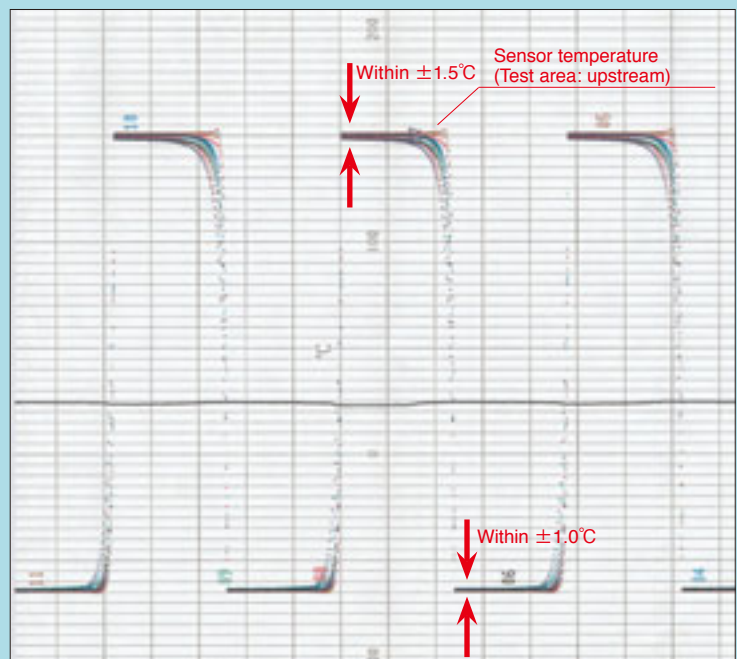

Characteristics



Control panel

Controller

Setting	Interactive key input by touch panel
Display	TFT Color LCD
Test patterns	RAM (selected entry): a maximum of 40 patterns can be entered ROM (built-in): contains 10 test standard patterns
Auxiliary functions	<ul style="list-style-type: none"> · Timer preset · Test continuity selection · Overheat/ Overcool protection · Upstream/ downstream sensor selection · Stable time control · Quick exposure control · Power recovery mode · Automatic defrost · Temperature recovery time setting · Program memory · Automatic power shut-off · Programmed time display · Test suspension · Test completion mode selection · Trend graph · Alarm history display · Sensor calibration · RS-485 communication

● Test area

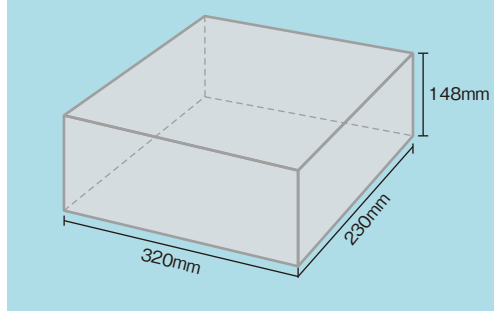

Cable port (50mm, shown with cap installed)

● Color LCD interactive touch-screen system

Operation and settings simplified by the use of a touch-screen LCD display (instructions displayed on-screen). At-a-glance confirmation of test patterns, test area temperatures, temperature cycles, upstream / downstream control, and trend graphs display.

● Large 10.9-liter-capacity test area

Features a 10.9-liter test area, twice that of our previous model. The volume that can be processed is greatly increased, and a 210 × 297mm printed circuit board can be tested in the horizontal position.

● Test area anti-drop mechanism

A braking system fitted to the drive mechanism prevents specimens from falling into the test area when the chamber stops operation. Other protection mechanisms are equipped to ensure that the specimen does not fall.

● Easy wiring access

A cable port is provided on the right side to allow easy wiring of specimens for measurement during high and low-temperature cycle tests.

● Comprehensive safety system

A dual safety system automatically stops the test area drive mechanism if the door is left open, and automatically locks the door when the test area is in motion.

● Equipped with casters for mobility

Characteristics

A whole range of environmentally-friendly features

● Reduced power consumption

Reduced power consumption is an important issue for our customers. This compact thermal shock chamber employs number of measures such as the use of electronic expansion valve to regulate the refrigeration capacity control. Specifically aimed at energy savings.

● Minimum footprint

Its slim design requires only 2.88m² installation space (31 ft²). Ideal for narrow spaces in labs or factories.

● Material labeling for easy recycling

Plastic molded components are labeled and easily detachable to make recycling easier for future disposal of the equipment.

● Paperless recorder (option)

Built-in paperless recorders is available to record temperatures from various sources, such as test area temperature. Recording is possible on Compact Flash Card or via USB port.

● Required footprint (Installation space: 2.88 m²)

Top view
Unit: mm

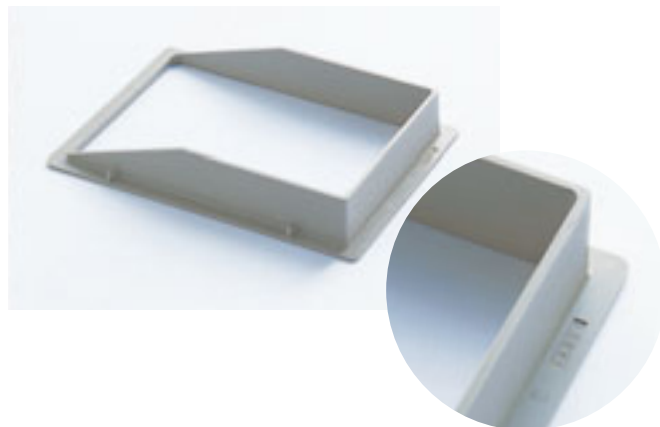
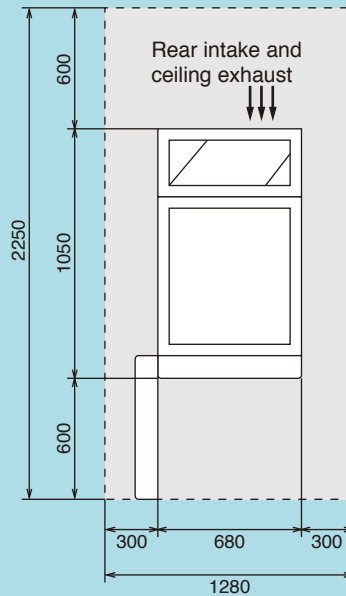

Paperless recorder (optional)

TEST STANDARD (TSE-11-A compliant)

Test standard	Exposure temperature			Exposure time		Temp. recovery time	Number of cycles	Test starting point	
	High temp.	Ambient temp.*	Low temp.	High/ low temp.	Ambient temp.*				
MIL-STD-883H (Method No. 1010.8)	A	+ 85°C ⁺¹⁰ ₀	—	- 55°C ⁰ ₋₁₀	more than 10 min.	—	Specimen temp within 15 min. at worst condition	Minimum 10 cycles	Low or high temp.
	B	+ 125°C ⁺¹⁵ ₀							
	C	+ 150°C ⁺¹⁵ ₀							
	D	+ 200°C ⁺¹⁵ ₀							
	F	+ 175°C ⁺¹⁵ ₀							
IEC 60068-2-14 (JIS C 60068-2-14)	+ 70°C ±2 + 85°C ±2 + 100°C ±2 + 125°C ±2 + 155°C ±2 + 175°C ±2 + 200°C ±2	Ambient temp.	- 5°C ±3 - 10°C ±3 - 25°C ±3 - 40°C ±3 - 55°C ±3 - 65°C ±3	3 hours 2 hours 1 hour 0.5 hour 3 hours if not specified	less than 10 sec.	less than 10% of exposure time	5 cycles if not specified	Low temp.	
JASO D 001	1	+ 85°C	Ambient temp.	- 40°C	Less than 0.2 kg 1 hour +15 min. 0	Short exposure is recommendable	Upstream of specimen within 5 min.	6 cycles	High temp.
	2	+ 75°C			0.2~0.8 kg 2 hours +15 min. 0				
	3	+120°C			0.8~1.5 kg 3 hours +15 min. 0 More than 1.5 kg 4 hours +15 min. 0				
EIAJ ED-2531A	+ 60°C ±2 + 65°C ±2 + 70°C ±2 + 75°C ±2 + 80°C ±2 + 85°C ±2 + 90°C ±2 + 95°C ±2 + 100°C ±2	Ambient temp.	0°C ±3 - 5°C ±3 - 10°C ±3 - 15°C ±3 - 20°C ±3 - 25°C ±3 - 30°C ±3 - 35°C ±3 - 40°C ±3 - 45°C ±3 - 50°C ±3	3 hours 2 hours 1 hour 0.5 hour 3 hours if not specified	less than 10 sec.	less than 10% of exposure time	5 or 10 cycles	Low temp.	

■ The above specification tests include only those tests applicable to TSE-11-A. For further information, please contact us.

* Ambient temperature at exposure temperature and exposure time represents the temperature and time when moving from hot chamber to cold chamber.

SPECIFICATIONS

Model		TSE-11-A				
System		2-zone transition by vertical transfer of specimen				
Performance ^{*1}	Test area	High temp. exposure range	+ 60 to +200°C (+140 to +392°F)			
		Low temp. exposure range	− 65 to 0°C (− 85 to +32°F)			
		Temperature fluctuation ^{*2}	±0.5°C (±0.9°F)			
	Hot chamber	Pre-heat upper limit	+200°C (+392°F)			
		Temp. heat-up time ^{*3}	Ambient temp. to +200°C (+392°F) within 30 min.			
	Cold chamber	Pre-cool lower limit	−80°C (−112°F)			
		Temp. pull-down time ^{*3}	Ambient temp. to −80°C (−112°F) within 90 min.			
	Temp. recovery	Recovery conditions	<ul style="list-style-type: none"> • 2 zones • High temperature exposure: +150°C (+302°F), 30 min. • Low temperature exposure: −65°C (−85°F), 30 min. • Sensor position: Upstream • Specimen: Plastic molded ICs 2 kg 			
		Temp. recovery time	within 5 min.			
	Construction	Test area	Shelf brackets on 2 levels of fixed location			
Heater		Stripped wire heater				
Refrigeration unit		System	Mechanical cascade refrigeration system			
		Compressor	Rotary 1.5 kW × 2			
		Refrigerant	R508A R404A			
		Condenser	Air-cooled condenser			
Cooler		Plate fin cooler, cold accumulator				
Air circulator	Sirocco fan					
Fittings	Specimen power supply control terminal, integrating hour meter without reset, time signal (2), cable port 50 mm, (right side), casters with leveling feet (4), power cable					
Test area load resistance	8 kg					
Specimen basket load capacity	2kg per basket (equally distributed load)					
Inside dimensions (W×H×D)	320×148×230mm (12.6×5.8×9 inch)					
Test area capacity	10.9 L					
Outside dimensions (W×H×D) ^{*4}	680×1625×1050mm (26.8×64×41.3 inch)					
Weight	approximately 390kg					
Allowable ambient conditions	0 to +40°C (+32 to +104°F)					
Power supply (Voltage fluctuation: rating ±10%)	200V AC 3 φ 3W 50/60Hz	220V AC 3 φ 3W 60Hz	380V AC 3 φ 4W 50Hz	400/415V AC 3 φ 4W 50Hz	400V AC ^{*5} 3 φ 4W 50Hz	
Maximum load current	26A	25A	17A	17A	17A	
Exhaust heat quantity ^{*6}	17,585kJ/h					
Noise level ^{*7}	60dB or less					

^{*1} The performance values are under the conditions of a +23°C ambient temperature, relative humidity of 65%rh, rated voltage, and no specimen. Heat up time and pull down time are those of single-unit operation of each chamber.

^{*2} The performance values are based on IEC60068-3-5:2001, JTM K07:2007.

^{*3} Temperature heat-up/pull-down time account for performance of each temperature chamber.

^{*4} Excluding protrusions.

^{*5} Compliance with CE Marking.

^{*6} At ambient temperature +23°C.

^{*7} At 1m from front of chamber, 1.2m from floor. (ISO 1996-1:2003 A-weighted sound pressure level) depending on environment



- Do not use specimens which are explosive or inflammable, or which contain such substances. To do so could be hazardous, as this may lead to fire or explosion.

- Do not place corrosive materials in the chamber. If corrosive substances or humidifying water is used, the life of the unit may be significantly shortened.

- Do not place life forms or substances that exceed allowable heat generation.



Be sure to read the user's manual before operation.

SAFETY DEVICES

- Leakage breaker (200, 220, 380, 400/ 415V AC)
- Circuit breaker (400V AC)
- Electrical compartment door switch
- Hot chamber overheat protection switch
- Cold chamber overheat protection switch
- Hot chamber overheat protector (Controller)
- Cold chamber overheat / overcool protectors (Controller)
- Test area overheat and overcool protectors (Built-in controller)
- Test area overheat / overcool protectors
- Refrigerator high pressure switch
- Thermal relay for compressor
- Temperature switch for compressor
- Temperature switch for air circulator
- Thermal relay for air circulator
- Motor inverter
- Motor reverse prevention relay
- Hot chamber door switch
- Cold chamber door switch
- Test area hold
- Door lock mechanisms
- Fuse
- Specimen power supply control terminal

ACCESSORIES

- Specimen basket (18-8 Cr-Ni stainless steel, 5 mesh metal basket)
W320×H35×D230mm
Load capacity: 2kg (equally distributed) 2
- Cartridge fuse (5 A) 1
- Cable port rubber plug 2
- Wirefisher 1
- User's manual (CD-R, booklet) 1 set

OPTIONS

Paperless recorder

Records temperature of each section such as the temperature inside the chamber.

Number of inputs:

PL1S: 1 (5 more channels can be turned ON)

Data saving cycle: 1 sec

PL3S: 3 (3 more channels can be turned ON)

Data saving cycle: 1 sec

PL3L: 3 (3 more channels can be turned ON)

Data saving cycle: 5 sec

Temperature range: -100°C to $+220^{\circ}\text{C}$

External memory:

CF memory card port

(Includes a 256MB CF card)

Language: ENG, JPN can be changed



Temperature recorder (digital display)

Temperature range:

-100 to $+220^{\circ}\text{C}$

Effective recording chart width:

100mm

- RK-61: 1pen
- RK-63: 3 pens
- RK-64: 6 dots



Recorder wiring

Preparation of a power cable, temperature sensor, and conductor grounding wire for additional installation in the future.

OPTIONS

Terminal for recorder

To output temperature values from the test area, hot chamber, cold chamber.

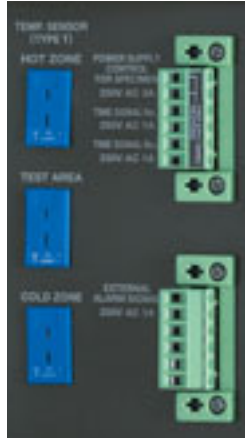

Specimen power supply control terminal

Time signal

External alarm terminal (option)

Thermocouple

Attached to specimens to measure specimen temperature.

- 2m
- 4m
- 6m

* T JIS C 1602 with ball attached

Auxiliary cooling injector (LCO₂)

Used to reduce the temperature recovery time of low temperature exposure by injecting liquefied carbon dioxide at the beginning of exposure.

Auxiliary cooling injector (LN₂)

Used to reduce the temperature recovery time of low temperature exposure by injecting liquefied nitrogen at the beginning of exposure.

Total cycle counter

Indicates cycle counts.
Display range: 1 to 99999999
(with reset function)



Additional overhear protector

Additional preventive measures can be taken for excessive temperature rise in the chamber, in addition to the standard equipped overhear protectors.

External alarm terminal

If the safety device of the chamber is activated, the external alarm terminal will notify it to a remote point.

Emergency stop pushbutton

Stops the chamber immediately.

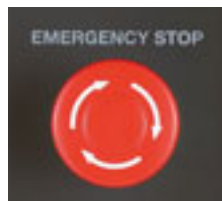

Cable port rubber plug

Prevents air leakage from the cable port.

Specimen basket

Equivalent to standard accessory.
• Material: stainless steel (5 mesh)



Anchoring fixtures

Used to bolt the chamber to the floor.

Power cable

Used to connect to the primary power source.

- 5m
- 10m

Color specification

Chamber can be painted to any desired color. (a color sample is required)

Interface

- Computer interface GPIB
 - Serial interface RS-232C
- *Select one, instead of standard RS-485.

Communication cable

- RS-485 5m/ 10m/ 30m
- GPIB 2m/ 4m
- RS-232C 1.5m/ 3m/ 6m

ESPEC CORP. <http://www.espec.co.jp/english>

Head Office

3-5-6, Tenjinbashi, Kita-ku, Osaka 530-8550, Japan
Tel: 81-6-6358-4741 Fax: 81-6-6358-5500

ESPEC NORTH AMERICA, INC.

Tel: 1-616-896-6100 Fax: 1-616-896-6150

ESPEC EUROPE GmbH

Tel: 49-89-1893-9630 Fax: 49-89-1893-96379

ESPEC (CHINA) LIMITED

Tel: 852-2620-0830 Fax: 852-2620-0788

ESPEC ENVIRONMENTAL EQUIPMENT (SHANGHAI) CO., LTD.

Head Office

Tel: 86-21-51036677 Fax: 86-21-63372237

BEIJING Branch

Tel: 86-10-64627025 Fax: 86-10-64627036

TIANJIN Branch

Tel: 86-22-26210366 Fax: 86-22-26282186

GUANGZHOU Branch

Tel: 86-20-83317826 Fax: 86-20-83317825

SHENZHEN Branch

Tel: 86-755-83674422 Fax: 86-755-83674228

SUZHOU Branch

Tel: 86-512-68028890 Fax: 86-512-68028860

ESPEC TEST TECHNOLOGY (SHANGHAI) CO., LTD.

Tel: 86-21-68798008 Fax: 86-21-68798088

ESPEC SOUTH EAST ASIA SDN.BHD.

Tel: 60-3-8945-1377 Fax: 60-3-8945-1287



QMS
JIS Q 9001
JSAQ 004



MS
JAB
CM001



MS
JAB
CM021



ISO 9001/JIS Q 9001

Quality Management System Assessed and Registered

ESPEC CORP. has been assessed by and registered in the Quality Management System based on the International Standard ISO 9001:2008 (JIS Q 9001:2008) through the Japanese Standards Association (JSA).

* Registration : ESPEC CORP.
(Overseas subsidiaries not included)

ISO 14001 (JIS Q 14001)

Environmental Management System Assessed and Registered

ESPEC CORP.

- Specifications are subject to change without notice due to design improvements.
- Corporate names and trade names mentioned in this catalog are trademarks or registered trademarks.